

OPERATOR'S SAFETY AND SERVICE MANUAL



AP/GP12, 15 & 18

This manual covers the following serial numbers
and higher for each model listed:

12.....	1121835
15.....	1160765
18.....	3180001



VIBRATORY PLATES

MBW, Inc.

250 Hartford Rd • PO Box 440
Slinger, WI 53086-0440
Phone: (262) 644-5234
Fax: (262) 644-5169
Email: mbw@mbw.com
Website: www.mbw.com

MBW (UK) Ltd.

Units 2&3 Cochrane Street
Bolton BL3 6BN, England
Phone: 44 (0) 01204 387784
Fax: 44 (0) 01204 387797
E-mail: saleseurope@mbw.com
Website: www.mbw europe.com

L20411 / 01.22.AB
©MBW, Inc. 2015
Printed in the USA

TABLE OF CONTENTS

SAFETY INFORMATION	1	SERVICE	7
Introduction	1	Torque Chart	7
Safety Precautions	1	Service Tools	7
Safety Decals	1	Engine Maintenance	7
SPECIFICATIONS	3	Engine RPM	7
OPERATION	4	Changing Exciter Oil	7
Introduction	4	Cleanup	7
Before Starting & Operating	4	Belt Adjustment	8
Starting Engine	4	Engine Removal	8
Operating	4	Exciter Disassembly	8
Stopping Engine	4	Exciter Assembly	8
Lifting/Transporting	4	Parts Replacement Cycles and Tolerances	9
MAINTENANCE	6	REPLACEMENT PARTS	10
Maintenance Schedule	6	Exciter Assembly	12
Fluid Levels	6	Main Assembly	14
Engine Maintenance	6	Handle Assembly	16
Engine Speed	6	Optional Equipment	18
		WARRANTY	20



WARNING



CALIFORNIA PROPOSITION 65 WARNING

Engine exhaust and some of its constituents and dust produced during the use of this product contain chemicals known in the state of California to cause cancer, birth defects, and other reproductive harm.

For more information go to **www.P65Warnings.ca.gov**

SAFETY INFORMATION

Introduction



This Safety Alert Symbol is used to call attention to items or operations which may be dangerous to those operating or working with this equipment.

The symbol can be found throughout this manual and on the unit. Please read these warnings and cautions, along with all decals, carefully before attempting to operate the unit. Make sure every individual who operates or works with this equipment is familiar with all safety precautions.

WARNING

GENERAL WARNING. Indicates information important to the proper operation of the equipment. Failure to observe may result in damage to the equipment and/or severe bodily injury or death.

CAUTION

GENERAL CAUTION. Indicates information important to the proper operation of the equipment. Failure to observe may result in damage to the equipment.

Safety Precautions



LETHAL EXHAUST GAS: An internal combustion engine discharges carbon monoxide, a poisonous, odorless, invisible gas. Death or serious illness may result if inhaled. Operate only in a properly ventilated area. **NEVER OPERATE IN A CONFINED AREA!**



DANGEROUS FUELS: Use extreme caution when storing, handling and using fuels as they are highly volatile and explosive in vapor state. Do not add fuel while engine is running. Stop and cool the engine before adding fuel. **DO NOT SMOKE!**



SAFETY GUARDS: It is the owner's responsibility to ensure that all guards and shields are in place and in working order.



IGNITION SYSTEMS: Breakerless, magneto, and battery ignition systems can cause severe electrical shocks. Avoid contacting these units or their wiring.



SAFE DRESS: Do not wear loose clothing, rings, wristwatches, etc. near machinery.



NOISE PROTECTION: Wear OSHA specified hearing protection devices.



EYE PROTECTION: Wear OSHA specified eye shields, safety glasses, and sweat bands.



FOOT PROTECTION: Wear OSHA specified steel-tipped safety shoes.

HEAD PROTECTION: Wear OSHA specified safety helmets.



OPERATOR: Keep children and bystanders off and away from the equipment.

DUST PROTECTION: Machining, crushing or handling of stone, concrete, masonry, metal and other materials may generate dust, mist and fumes containing chemicals such as silica

known to cause serious or fatal injury or illness such as respiratory disease, silicosis, cancer, birth defects, or other reproductive harm.

- Control dust, mist and fumes at the source where possible. Water should be used to control dust whenever feasible.
- Use good work practices and follow the recommendations of the manufacture, OSHA/NIOSH and other occupational trade associations.
- When hazards cannot be eliminated the operator and any bystanders should always wear a OSHA specified respirator for materials being handled.

REFERENCES: For details on safety rules and regulations in the United States, contact your local Occupational Safety and Health Administration (OSHA) office. Equipment operated in other countries must be operated and serviced in accordance and compliance with any and all safety requirements of that country. The publication of these safety precautions is done for your information. MBW does not by the publication of these precautions, imply or in any way represent that these are the sum of all dangers present near MBW equipment. If you are operating MBW equipment, it is your responsibility to insure that such operation is in full accordance with all applicable safety requirements and codes. All requirements of the United States Federal Occupational Safety and Health Administration Act must be met when operated in areas that are under the jurisdiction of that United States Department.

Safety Decals

Carefully read and follow all safety decals. Keep them in good condition. If decals become damaged, replace as required. If repainting the unit, replace all decals. Decals are available from authorized MBW distributors. Order the decal set listed on the following page.

WARNING
 Operating, servicing and maintaining this equipment can expose you to chemicals, including engine exhaust, phthalates and lead, which are known to the state of California to cause cancer and birth defects or other reproductive harm. Avoid breathing engine exhaust. Do not operate equipment in confined areas. For more information go to www.P65Warnings.ca.gov

21820

CAUTION
 Unit may fall and cause injury or damage if lifted improperly. Use handles on deck and base plate to lift.

GP12 = 137 lbs (62kg)	AP12 = 158 lbs (72kg)
GP15 = 145 lbs (66kg)	AP15 = 166 lbs (75kg)
GP18 = 180 lbs (82kg)	AP18 = 202 lbs (92kg)

20420

WARNING
 OPERATION OF THIS EQUIPMENT MAY CREATE SPARKS THAT CAN START FIRES AROUND DRY VEGETATION. A SPARK ARRESTER MAY BE REQUIRED. THE OPERATOR SHOULD CONTACT LOCAL FIRE AGENCIES FOR LAWS OR REGULATIONS RELATING TO FIRE PREVENTION

19791

MBW

22531

AP12

20787-GP15 - 21196-AP15

20786-GP12 - 21195-AP12

20788-GP18 - 21197-AP18

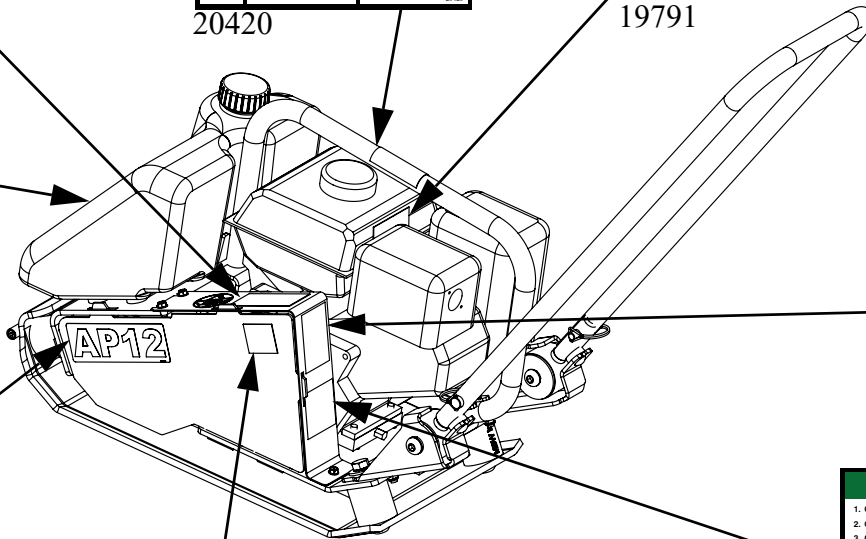

WARNING
 ROTATING PARTS can crush and cut. Keep hands away!

12573



21742

PLATES OPERATING INSTRUCTIONS

1. Check engine oil.
2. Open fuel valve.
3. Choke engine. A warm engine may not need to be choked.
4. Open throttle part way.
5. Pull starter rope.
6. After starting; open choke, return throttle to idle position.
7. During operation, when excessive kickback is noticed, maximum compaction has been reached.
8. To stop; Return throttle to idle position, use engine stop switch, close fuel valve.

13482

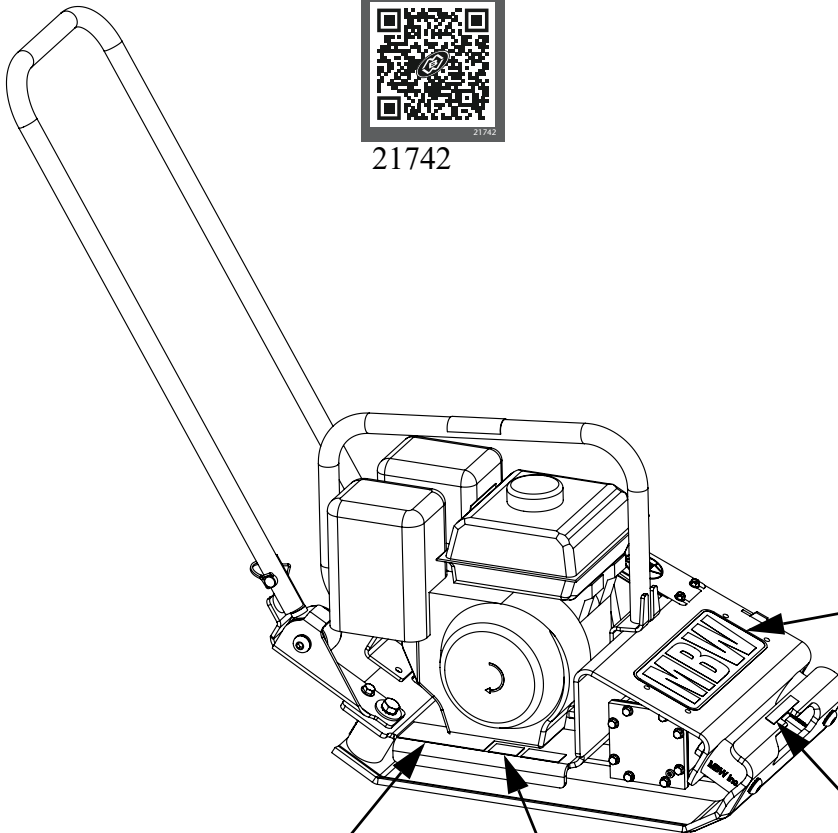

MBW

22531

U.S. PATENT 9,677,240
 21490 PLATE, 1000 SERIES

21490

CAUTION
 Read the Operating Instructions before operating this piece of equipment.
 Keep unauthorized and untrained people away from this equipment.
 ROTATING & MOVING PARTS! Make sure all guards and safety devices are in place.
 Avoid breathing dust from operating machine, wear OSHA specified dust mask/respirator.
 Failure to comply could result in serious bodily injury.

20019

REMINDER
 Change engine oil every 50 hours.

22590 - GX160 ENGINE ONLY

Safety Decals (Decal Set #12100)

SPECIFICATIONS

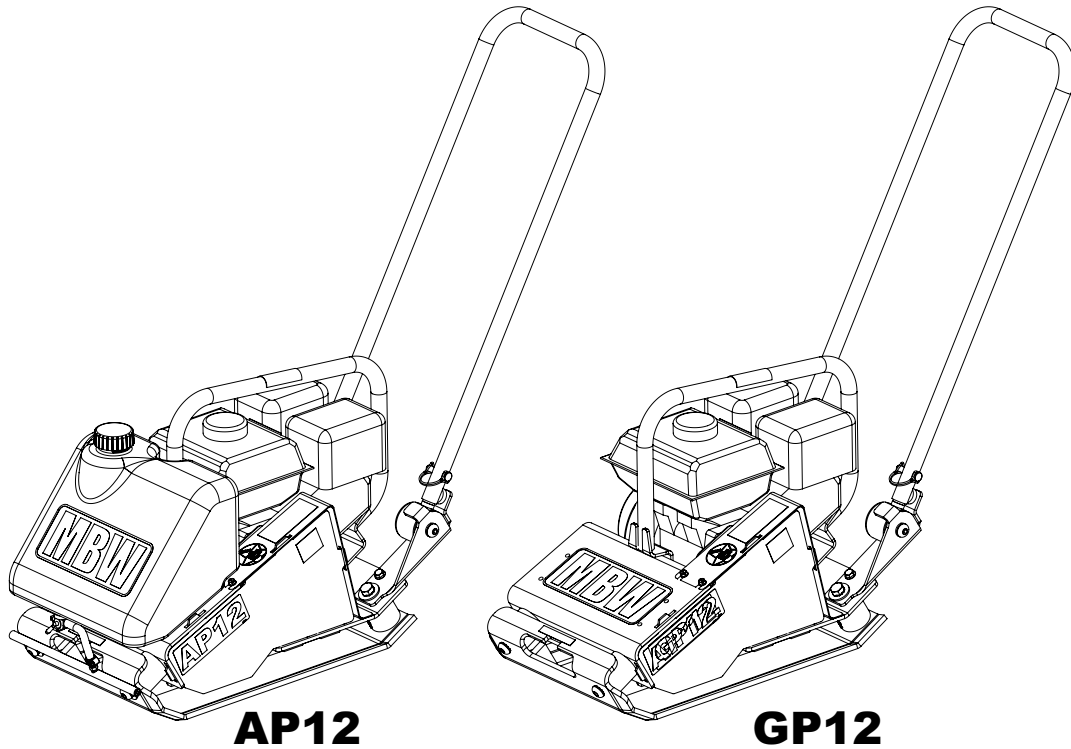

AP12

GP12

	AP12	GP12	AP15	GP15	AP18	GP18
CENTRIFUGAL FORCE	1920 lbs (873 kg)	1920 lbs (873 kg)	2000 lbs (898 kg)	2000 lbs (898 kg)	2780 lbs (1261kg)	2780 lbs (1261kg)
EXCITER (VPM)	5240	5240	5350	5350	5240	5240
TRAVEL SPEED	83ft./min. (25m/min.)	83ft./min. (25m/min.)	68ft./min. (21m/min.)	68ft./min. (21m/min.)	75ft./min. (23m/min.)	75ft./min. (23m/min.)
COMPACTION DEPTH	10 in. (25 cm)	10 in. (25 cm)	10 in. (25 cm)	10 in. (25 cm)	10 in. (25 cm)	10 in. (25 cm)
WIDTH & LENGTH	13 x 22.5 in. (33 x 57 cm)	13 x 22.5 in. (33 x 57 cm)	16 x 22.5 in. (40 x 57 cm)	16 x 22.5 in. (40 x 57 cm)	18 x 22.5 in. (46 x 57 cm)	18 x 22.5 in. (46 x 57 cm)
OPERATING WEIGHT	139 lbs/63 kg no water 158 lbs/72 kg full water	137 lbs (62 kg)	147 lbs/67 kg no water 166 lbs/75 kg full water	145 lbs (66 kg)	183 lbs/83 kg no water 202 lbs/92 kg full water	174 lbs (79 kg)
ENGINE SPEED (RPM)	3400	3400	3475	3475	3400	3400
WATER TANK CAPACITY	2.3 gal. (8.7 l)		2.3 gal. (8.7 l)		2.3 gal. (8.7 l)	
NOISE LEVEL	84-94 dBA					
ENGINE OPTIONS	HONDA GX120 (118 cm) ³				HONDA GX160 (163 cm) ³	

Specifications subject to change without notice

- No universal method or formula has been accepted for determining "Compaction Force". All manufactures employ their own method or formula.

OPERATION

Introduction

MBW equipment is intended for use in very severe applications. They are powered by four cycle engines and are available in different sizes and a selection of engines.

This parts manual contains only standard parts. Variations of these parts as well as other special parts are not included. Contact your local MBW distributor for assistance in identifying parts not included in this manual.

The MBW GP12, GP15, GP18 compactors are intended to compact various types of soil. Recommended soil types include granular soils and gravel & sand mixtures. These compactors are not intended to be used on cohesive soils such as clay or hard surfaces like concrete.

Before Starting & Operating

- REMEMBER! It is the owner's responsibility to communicate information on the safe use and proper operation of this unit to the operators.
- Review ALL of the Safety Precautions listed on page 1 of this manual.
- Familiarize yourself with the operation of the machine and confirm that all controls function properly.
- Know how to STOP the machine in case of an emergency.
- Make sure hands, feet, and clothing are at a safe distance from any moving parts.
- OIL LEVEL - Check the oil level in the engine. For more information see "Lubrication" under the respective engine's "Owners Manual" or the Maintenance section of this manual.
- AIR CLEANER - Check to ensure element is in good condition and properly installed.
- FUEL SUPPLY - The engines on MBW equipment require an automotive grade of clean, fresh, unleaded gasoline.
- FUEL FILTER - If clogged or damaged, replace.

Starting Engine

1. Open fuel valve.
2. Turn engine switch to "ON".
3. Set throttle to idle.
4. Choke engine if necessary (you may not need to choke a warm engine).
5. Pull starter rope repeatedly until engine starts.
6. After starting engine, open choke gradually and let engine warm up at idle.

Operating

1. After engine warms up open fully open throttle. The compactor will begin vibrating and moving forward. The number of passes required to reach a desired compaction level will depend on the type and moisture content of soil. Maximum soil compactions has been reached when excessive kickback is noticed in the compactor.
2. When using a compactor on asphalt a water sprinkling system is required to help prevent the bottom plate from adhering to the hot asphalt surface.

Stopping Engine

1. Move throttle to idle position.
2. Let engine idle for one or two minutes.
3. Turn switch on engine to "STOP" position.
4. Turn off fuel valve.

Lifting/Transporting

1. The unit can be lifted by the handles in front and back of the unit as shown in figure 2.
2. The unit must be transported in the upright position. DO NOT lay machine on its side or top.
3. Secure or tie down unit using the lifting handles.



WARNING



Always stop the engine before:

Adding fuel.

Leaving the equipment unattended for any amount of time.

Before making any repairs or adjustments to the machine.

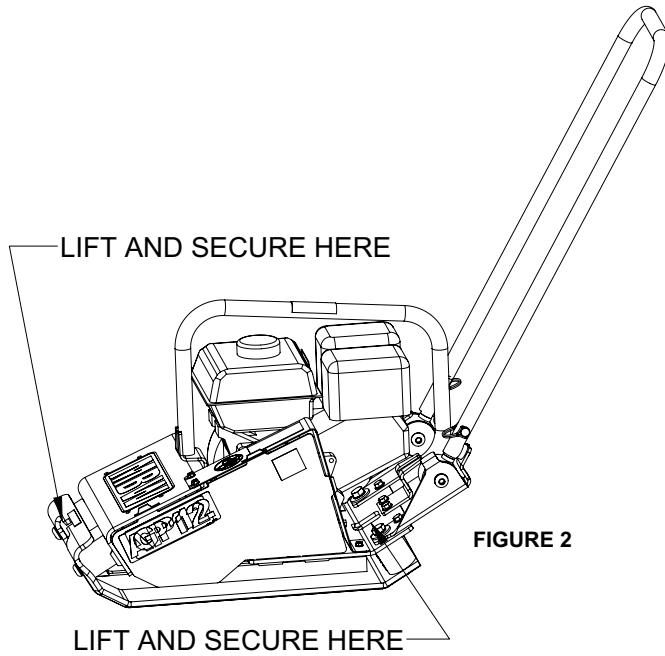

MAINTENANCE



WARNING



Always exercise the stopping procedure before servicing or lubricating the unit.

After servicing the unit, replace and fasten all guards, shields, and covers to their original positions before resuming operation.



CAUTION



Always verify fluid levels and check for leaks after changing fluids.

Do not drain oil onto ground, into open streams, or down sewage drains.

Maintenance Schedule

SYSTEM	MAINTENANCE	EACH USE	EVERY 50 HOURS	EVERY 250 HOURS	YEARLY
Engine	Refer to engine operator/owner manual	X			
	Change oil		HONDA GX160		
Exciter	Check for oil leaks	X			
	Change oil			X	X
	Tighten Bolts ¹		X		X
Hardware	Check and tighten as needed ¹		X		X
Shock Mounts	Check for cracks or tears		X		X

1. Check all hardware after the first 5 hours of use, then follow the maintenance schedule.

Fluid Levels

SYSTEM	FLUID VOLUME	RECOMMENDED OIL
Exciter	2 oz (GP12 &15) 1.5 oz (GP18)	MBW Ground Pounder® Exciter Oil ¹
Engine	Refer to engine operator/owner manual	

1. MBW #01058----- 6-Pack (8 oz bottles)
MBW #17320----- 1 quart (32 oz)

Engine Maintenance

Refer to the engine owner's manual for maintenance intervals and procedures.

Engine Speed

1. The engine speed is factory set according to the specifications section of this manual. Do not tamper with the governor setting. The governor establishes safe operating limits which must not be exceeded.

SERVICE

Assembly and disassembly should be performed by a service technician who has been factory trained on MBW equipment. The unit should be clean and free of debris. Pressure washing before disassembly is recommended.

- Prior to assembly, wash all parts in a suitable cleaner or solvent.
- Check moving parts for wear and failure. Refer to the Replacement section in this manual for tolerance and replacement cycles.
- All shafts and housings should be oiled prior to pressing bearings. Also, ensure that the bearings are pressed square and are seated properly.
- All bearings should be replaced when rebuilding any exciter or gearbox.
- All gaskets and seals should be replaced after any disassembly.

Torque Chart

SIZE	GRADE 2	GRADE 5	GRADE 8
1/4-20	49 in·lbs	76 in·lbs	9 ft·lbs
1/4-28	56 in·lbs	87 in·lbs	10 ft·lbs
5/16-18	8 ft·lbs	13 ft·lbs	18 ft·lbs
5/16-24	9 ft·lbs	14 ft·lbs	20 ft·lbs
3/8-16	15 ft·lbs	23 ft·lbs	33 ft·lbs
3/8-24	17 ft·lbs	26 ft·lbs	37 ft·lbs
7/16-14	24 ft·lbs	37 ft·lbs	52 ft·lbs
7/16-20	27 ft·lbs	41 ft·lbs	58 ft·lbs
1/2-13	37 ft·lbs	57 ft·lbs	80 ft·lbs
1/2-20	41 ft·lbs	64 ft·lbs	90 ft·lbs
9/16-12	53 ft·lbs	82 ft·lbs	115 ft·lbs
5/8-11	73 ft·lbs	112 ft·lbs	159 ft·lbs
5/8-18	83 ft·lbs	112 ft·lbs	180 ft·lbs
M 6	3 ft·lbs	4 ft·lbs	7 ft·lbs
M 8	6 ft·lbs	10 ft·lbs	18 ft·lbs
M 10	10 ft·lbs	20 ft·lbs	30 ft·lbs

CONVERSIONS

in·lbs x 0.083 = ft·lbs

ft·lbs x 12 = in·lbs

ft·lbs x 0.1383 = kg·m

ft·lbs x 1.3558 = N·m

Service Tools

Part No.	Description
01629	Test Mat
12100	Decal Set

Engine Maintenance

1. Refer to engine Owner's Manual for maintenance schedule.
2. Change engine oil every 50 hours, for Honda GX160 engine only.

Engine RPM

1. Refer to the engine Owner's Manual for procedure to set the operating and idle speed.
2. The engine operating speed should be set to the RPM listed in the Specifications section (Page 3).
3. The engine idle speed should not exceed 1800 RPM. If the idle speed is greater than 1800 RPM the clutch may not disengage.

Changing Exciter Oil

Refer to **EXCITER ASSEMBLY**, page 12.

1. Allow machine to completely cool down before performing any service or maintenance.
2. Clean debris from exciter, engine deck and base plate.
3. Remove drain plug (Figure 3), and tilt plate to the right so the oil drains from the exciter housing into a pan.
4. After the oil is drained, tilt the plate to the left and wipe any excess oil from the plate. Do not get debris in the exciter drain hole.
5. Fill the exciter housing with MBW Inc. Grounder Pounder® exciter oil according to the fluid level specified in the Maintenance section of this manual. **DO NOT OVERFILL - over filling can result in excessive temperatures in the exciter.**
6. Apply pipe sealant to the plug and reinstall.
7. Discard the used oil and any contaminated debris in a proper container.

Cleanup

1. Remove dirt and debris from plate daily.
2. If repainting plate, be sure that all decals are masked.

3. Replace any decals that are damaged.

Belt Adjustment

Refer to Main Assembly, page 15.

1. Remove hardware(#19) securing painted belt guard (#12) to engine deck and remove belt guard. Remove plastic belt guard (#9) for full access to belt.
2. Apply moderate thumb pressure to belt about half way between pulleys. When properly adjusted the belt should deflect approximately 3/8" (9mm). If the belt is adjusted correctly reinstall belt guard and hardware.
3. To adjust belt tension loosen the four hex head cap screws (#21) screws securing engine to engine deck.
4. Push engine towards the back of the plate. While holding pressure on the engine retighten the four hex head cap screws (#21) securing engine to engine deck.
5. Recheck belt tension as described in Step 2 and readjust if necessary until the proper tension is reached.
6. Reinstall belt guards (#9, #12), using hardware from Step 1.

Engine Removal

Refer to Main Assembly, page 15.

1. Remove hardware and belt guards as described in earlier section.
2. Remove the four bolts (#21) securing engine to engine deck.
3. Slide engine forward and remove belt (#2) and engine (#3).

Exciter Disassembly

Refer to Main Assembly, page 15.

1. Remove engine (#3) and belt guards (#2) as described in earlier section.
2. Remove the four screws (#21) securing engine deck to shock mounts/base plate and remove engine deck.
3. Clean the entire baseplate to remove all dirt and debris.
4. Drain exciter oil as described in Changing Exciter Oil section of this manual.

Refer to EXCITER ASSEMBLY, page 12.

5. Remove set screws (#16) securing pulley to exciter shaft. Remove pulley (#5) and shaft key (#4).
6. Remove hex head flange screws (#15) securing exciter covers (#9, #10) to exciter housing. Remove exciter covers and gaskets (#11).

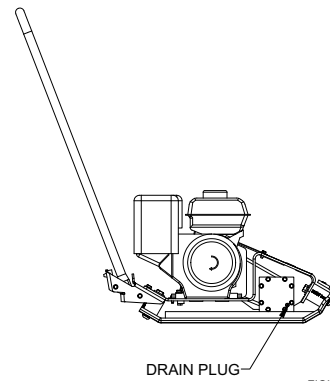

7. Remove exciter shaft (#8) by pressing the opposite of pulley end of the exciter shaft towards the opposite side of the housing. This will push the exciter shaft and the bearing on the pulley side out of the exciter housing. Press the bearing off of the exciter shaft.
8. Press the remaining bearing out of the exciter housing.
9. **GP18 only**, remove and replace internal snap ring (#7) if required.
10. Check bearings (#12, #13) for wear and replace if necessary as described in Parts Replacement Cycles and Tolerances section of this manual.

Exciter Assembly

Refer to EXCITER ASSEMBLY, page 12.

1. Prior to assembly, clean all parts in a suitable solvent cleaning solution.
2. Inspect all part for wear or failure and replace if necessary as described in Parts Replacement Cycles and Tolerances section of this manual.
3. Replace all seals and gaskets at every overhaul or disassembly.
4. All shafts and housings should be oiled prior to pressing in bearings. Ensure that all bearings and seals are pressed squarely and properly seated.
5. For proper hardware torque setting refer to Torque Chart table in this section of the manual.
6. Press bearing (#12) onto the pulley side of the exciter shaft.
7. **GP18 only**, install retaining ring (#7) into exciter housing opposite of the pulley side.
8. Press bearing (#13) into the exciter housing opposite of the pulley side.
9. Support the bearing in the exciter housing while pressing the exciter shaft (#8) into the housing. Press the exciter shaft into the housing until the bearing on the pulley side of the shaft is properly seated in the housing.
10. Install a new seal (#3) into the pulley side exciter cover (#9). Lubricate lip of seal with fresh exciter oil.

11. Assemble a new gasket (#11) and pulley side exciter cover (#9) to the exciter housing.
12. Assemble opposite side exciter cover (#10) and new gasket (#11) to exciter housing. Install hex head flange screws (#15).
13. Install shaft key (#4) and slide pulley (#5) onto exciter shaft (#8). Apply medium strength loctite to the set screws (#16), torque to 8 ft./lb., make sure the exciter shaft turns freely.
14. Fill exciter housing with oil as described in Changing Exciter Oil section of this manual.

Parts Replacement Cycles and Tolerances

Bearings	Replace anytime a bearing is rough, binding, discolored or removed from housing or shaft.
Clutch	Replace clutch if it does not disengage below 1800 rpm.
Engine Components	Refer to your engine manufacturer's Owner's Manual.
Hardware	Replace any worn or damaged hardware as needed. Replacement hardware should be grade 5 and zinc plated unless otherwise specified.
Safety Decals	Replace if they become damaged or illegible.
Seals & Gaskets	Replace if a leak is detected and at every overhaul or teardown.
V-Belts	Replace if cracked, torn, or stretched to the point the belt won't tension properly.
Exciter Oil	Replace once every season or every 250 hours. Use 2 ounces of oil from the 6-pack of MBW Inc. #01058 Grounder Pounder® Exciter Oil.

REPLACEMENT PARTS

The warranty is stated in this book on page 20. Failure to return the Warranty Registration Card renders the warranty null and void.

MBW has established a network of reputable distributors/dealers with trained mechanics and full facilities for maintenance and rebuilding, and to carry an adequate parts stock in all areas of the country. Their sales engineers are available for professional consultation. If you cannot locate an MBW distributor in your area, contact MBW or one of our Sales Branches listed below.

When ordering replacement parts, be sure to have the following information available:

- Model and Serial Number of machine when ordering MBW parts
- Model and Serial Number of engine when ordering engine parts
- Part Number, Description, and Quantity
- Company Name, Address, Zip Code, and Purchase Order Number
- Preferred method of shipping

REMEMBER - You own the best! If repairs are needed, use only MBW parts purchased from authorized MBW distributors.

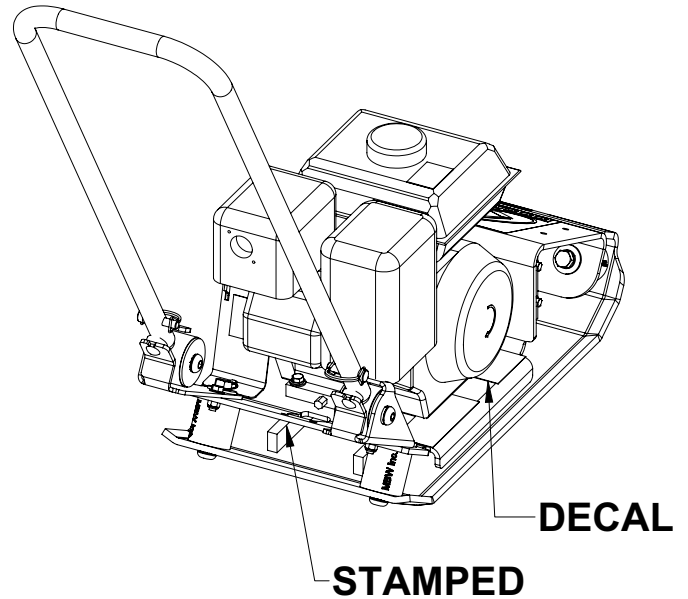

The unit's serial number can be found in the following locations:

- The model/serial number decal is located on the front right side of the engine deck.
- The serial number is stamped on the top of the left rail of the base plate.

Write Model Number here

Write Serial Number here

Contact Information

MBW, Inc.

250 Hartford Rd • PO Box 440
Slinger, WI 53086-0440
Phone: (262) 644-5234
Fax: (262) 644-5169
Email: mbw@mbw.com
Website: www.mbw.com

MBW (UK) Ltd.

Units 2 & 3 Cochrane Street
Bolton BL3 6BN, England
Phone: 01204 387784
Fax: 01204 387797
Email: saleseurope@mbw.com
Website: www.mbweurope.com

This page intentionally left blank.

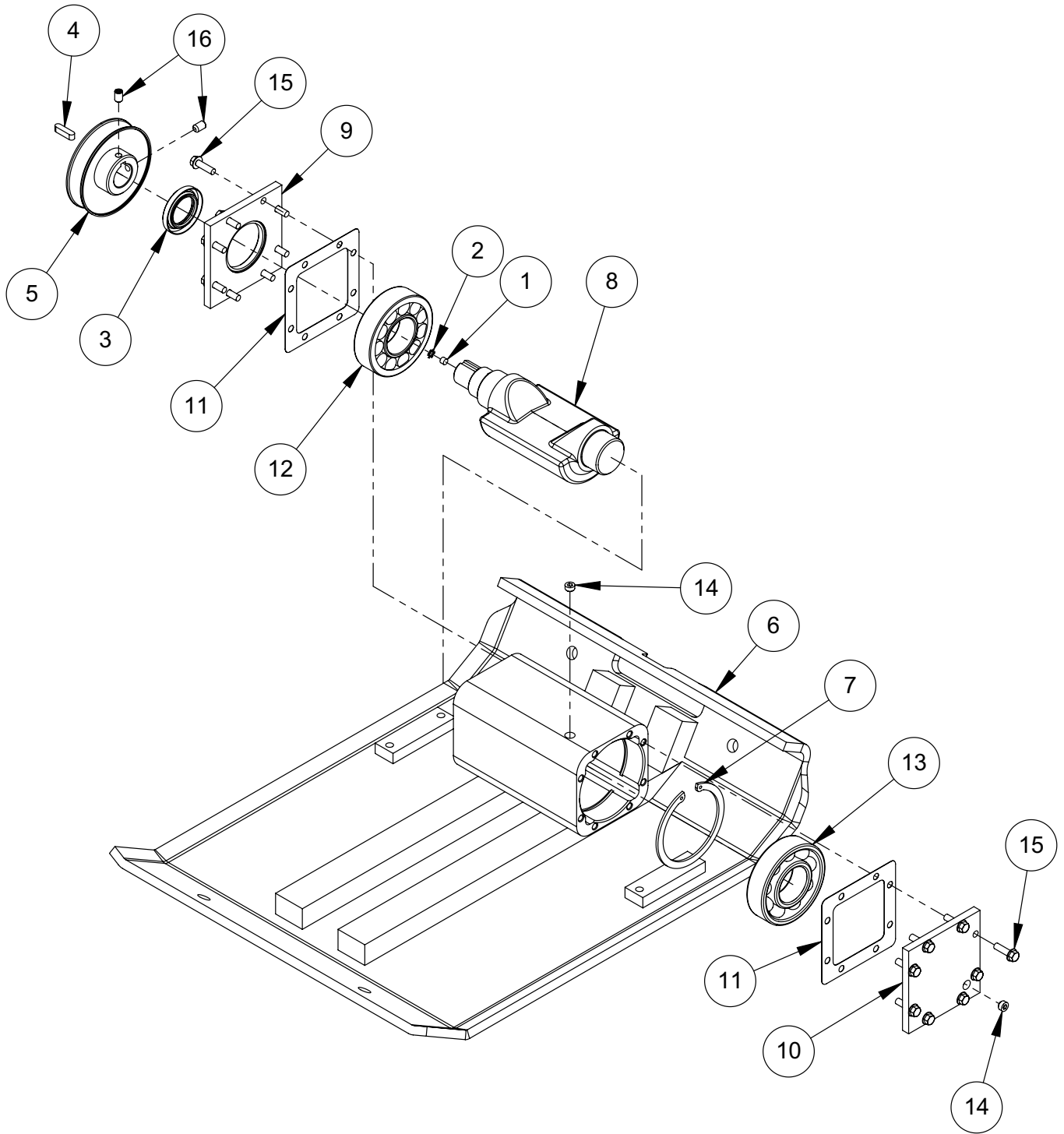

Exciter Assembly

ITEM	PART NO.	DESCRIPTION	GP12	GP15	GP18
1.	01072	FILTER, FELT	1	1	1
2.	01191	RETAINING RING, INTERNAL	1	1	1
3.	17179	SEAL, SHAFT, 1.25"	1	1	
	20379	SEAL, SHAFT, 1.25" (VITON) (GP18 ONLY)			1
4.	06335	KEY, 1/4 SQ X 1" LG	1	1	1
5.	19630	PULLEY, EXCITER, 1.0 X 3.88	1	1	1
6.	20751	BOTTOM PLATE WELDMENT	1		
	20408	BOTTOM PLATE WELDMENT		1	
	20531	BOTTOM PLATE WELDMENT			1
7.	20538	RETAINING RING, INT. 3.5 (GP18 ONLY)			1
8.	20756	EXCITER SHAFT, MACHINED	1	1	
	20536	EXCITER SHAFT, MACHINED (GP18 ONLY)			1
9.	20757	COVER, SEAL SIDE	1	1	1
10.	20758	COVER, FILLER SIDE	1	1	1
11.	20760	GASKET	2	2	2
12.	16395	BEARING, ROLLER, (GP18 ONLY)			1
13.	20776	BEARING 6308	2	2	1
14.	F0227SPP	SOCKET PIPE PLUG, 1/8-27	2	2	2
15.	F042007FWS	FWLS, 1/4-20 X 7/8, ZP	16	16	16
16.	F051804SSS	SSS, 5/16-18 X 1/2"	2	2	2

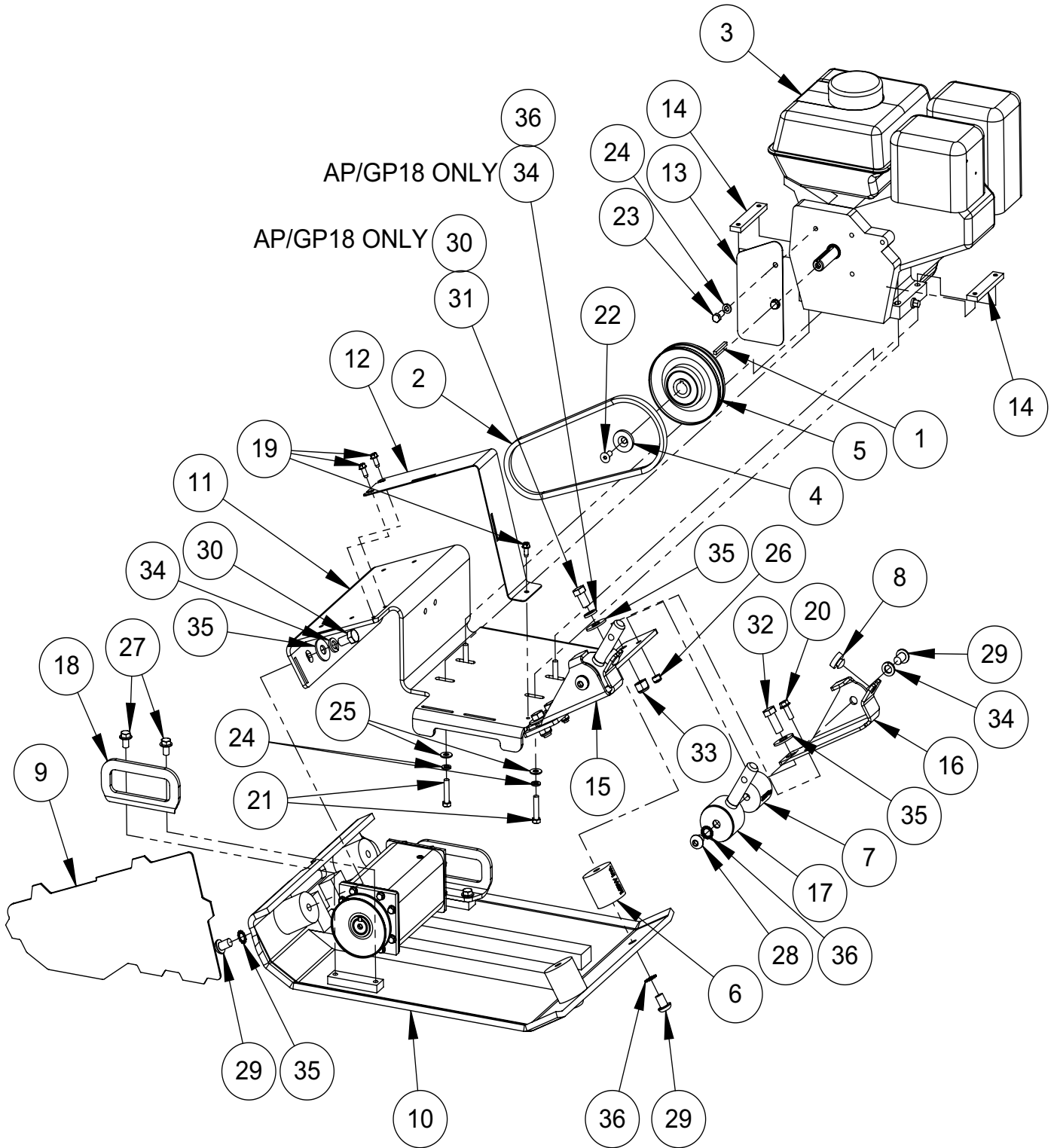

Main Assembly

ITEM	PART NO.	DESCRIPTION	GP12	GP15	GP18
1.	00032	KEY, 3/16" SQ. x 1-5/8 LG.	1	1	1
2.	01289	V-BELT (A-27) (AP/GP18 Serial No. #1181585 and lower)	1	1	
	22164	V-BELT (4L295) (AP/GP18 Serial No. #3180001 and above)			1
3.	12860	ENGINE, HONDA, GX120	1	1	
	01444	ENGINE, HONDA, GX160			1
4.	14993	WASHER, COUNTERSUNK	1	1	1
5.	16105	CLUTCH, CENTRIFUGAL	1	1	1
6.	16908	SHOCK MOUNT, 2" OD X 2-1/8" LG	4	4	4
7.	17170	SHOCK MOUNT, 2" OD X 1-3/4" LG	2	2	2
8.	20537	BUMPER, 1" DIA.	2	2	2
9.	20759	BELTGUARD, PLASTIC	1	1	1
10.	20768	BOTTOM PLATE ASSEMBLY (12")	1		
	20426	BOTTOM PLATE ASSEMBLY (15")		1	
	20530	BOTTOM PLATE ASSEMBLY (18")			1
11.	20771	ENGINE DECK (AP/GP18 Serial No. #1181585 and lower)	1	1	
	22170	ENGINE DECK (AP/GP18 Serial No. #3180001 and above)			1
12.	20772	BELT GUARD, PAINTED	1	1	1
13.	20773	GUARD, REAR, PAINTED	1	1	1
14.	20789	ENGINE MOUNTING BAR	2	2	2
15.	21016	HANDLE BRACKET, LEFT	1	1	1
16.	21018	HANDLE BRACKET, RIGHT	1	1	1
17.	21021	HANDLE MOUNTING BRACKET	2	2	2
18.	22174	LIFT HANDLE, (Serial No. #3180001 and above)			2
19.	F042005TCS	THREAD CUTT SCREW, 1/4-20 X 5/8 ZP	3	3	3
20.	F051807FWS	FLANGE WHIZ-LOCK SCREW, 5/16-18x7/8 ZP	2	2	2
21.	F051812HCS	HEX HEAD SCREW, 5/16 -18 X 1-1/2 GR5 ZP	4	4	4
22.	F052406FSS	FLAT HEAD SCREW 5/16-24 x 3/4"	1	1	1
23.	F052406HCS	HHCS 5/16-24 x 3/4 GR5 ZP	2	2	2
24.	F05LW	LOCKWASHER, 5/15 ZP	6	6	6
25.	F05SW	WASHER, 5/16 X 3/4 X 15 GAUGE ZP	4	4	4
26.	F0518ELN	LOCKNUT, 5/16-18 NYLOC ZP	2	2	2
27.	F061605FWS	FLANGE WHIZ-LOCK SCREW, 3/8-16 X 5/8" LG. ZP			4
28.	F081304BCS	BUTTON HEAD SCREW 1/2-13 X 1/2	2	2	2
29.	F081306BCS	BUTTON HEAD SCREW 1/2-13 X 3/4	6	6	6
30.	F081307HCS	HEX HEAD SCREW, 1/2-13 x 7/8 GR5 ZP	2	2	4
31.	F081308HCS	HEX HEAD SCREW, 1/2-13 x1 LG. GR5 ZP	2	2	
32.	F081310HCS	HEX HEAD SCREW, 1/2-13 x1-1/4 LG. GR5 ZP			2
33.	F0813ELN	LOCK NUT, 1/2-13 NYLOC, ZP			2
34.	F08LW	LOCKWASHER, 1/2 ZP	4	4	4
35.	F08SW	FLAT WASHER, 1/2 ZP	4	4	4
36.	M12ETLW	LOCK WASHER, M12, EXTERNAL TOOTH	8	8	8

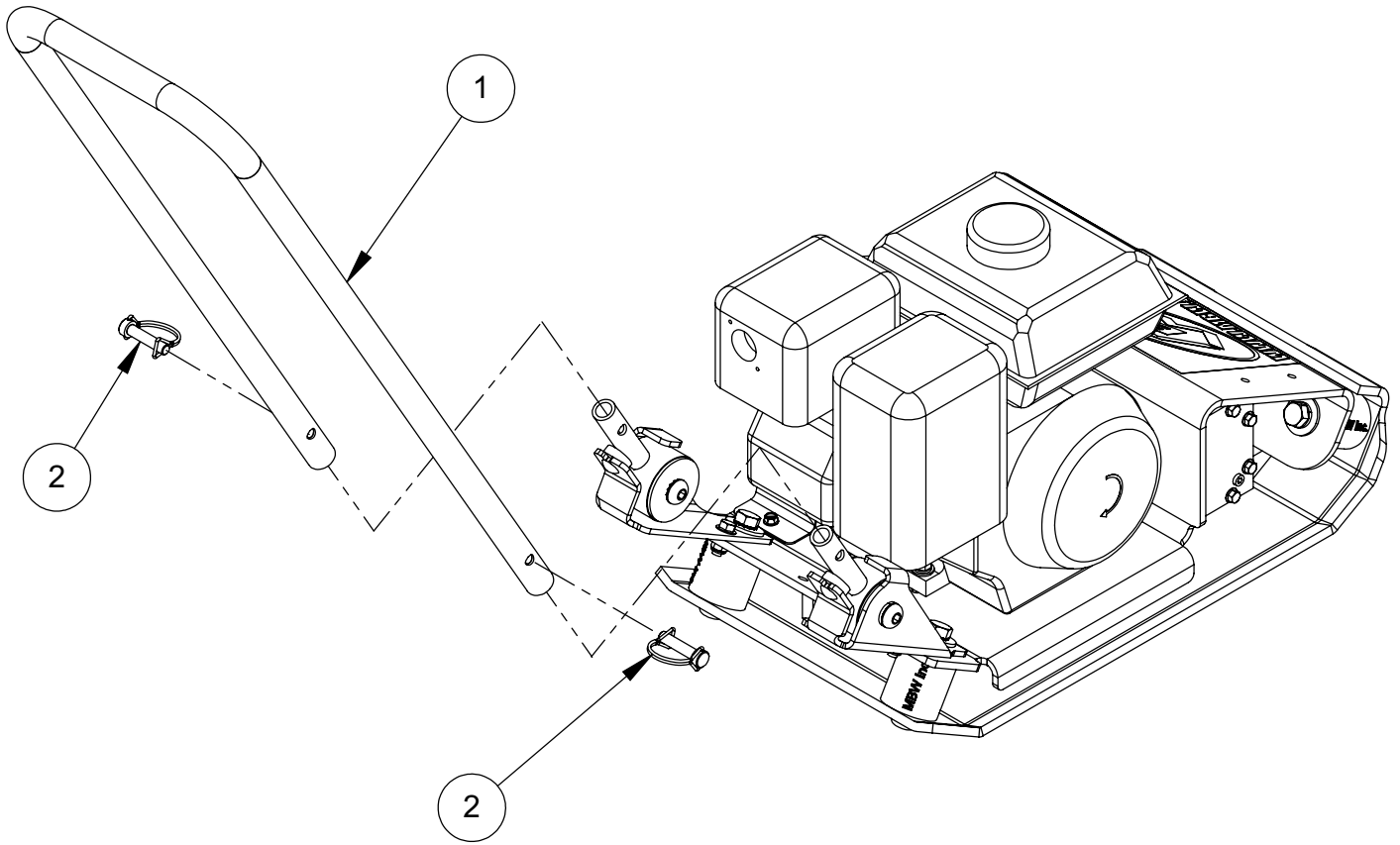

Handle Assembly

ITEM	PART NO.	DESCRIPTION	GP15	GP15	GP18
1.	21020 22169	HANDLE, COATED (AP/GP18 Serial No. #1181585 and lower) HANDLE, COATED (Serial No. #3180001 and above)	1	1	1
2.	21025	CLEVIS PIN	2	2	2
	21015	HANDLE KIT, Includes items 1 & 2 (Serial No. 1120780, 1160300 & <u>1180600 and above</u>)	1	1	1
	20763	HANDLE KIT: (Serial No. #1120779, 1160299 & 1180599 and lower)	1	1	1
	22168	HANDLE KIT (Serial No. #3180001 and above)			1

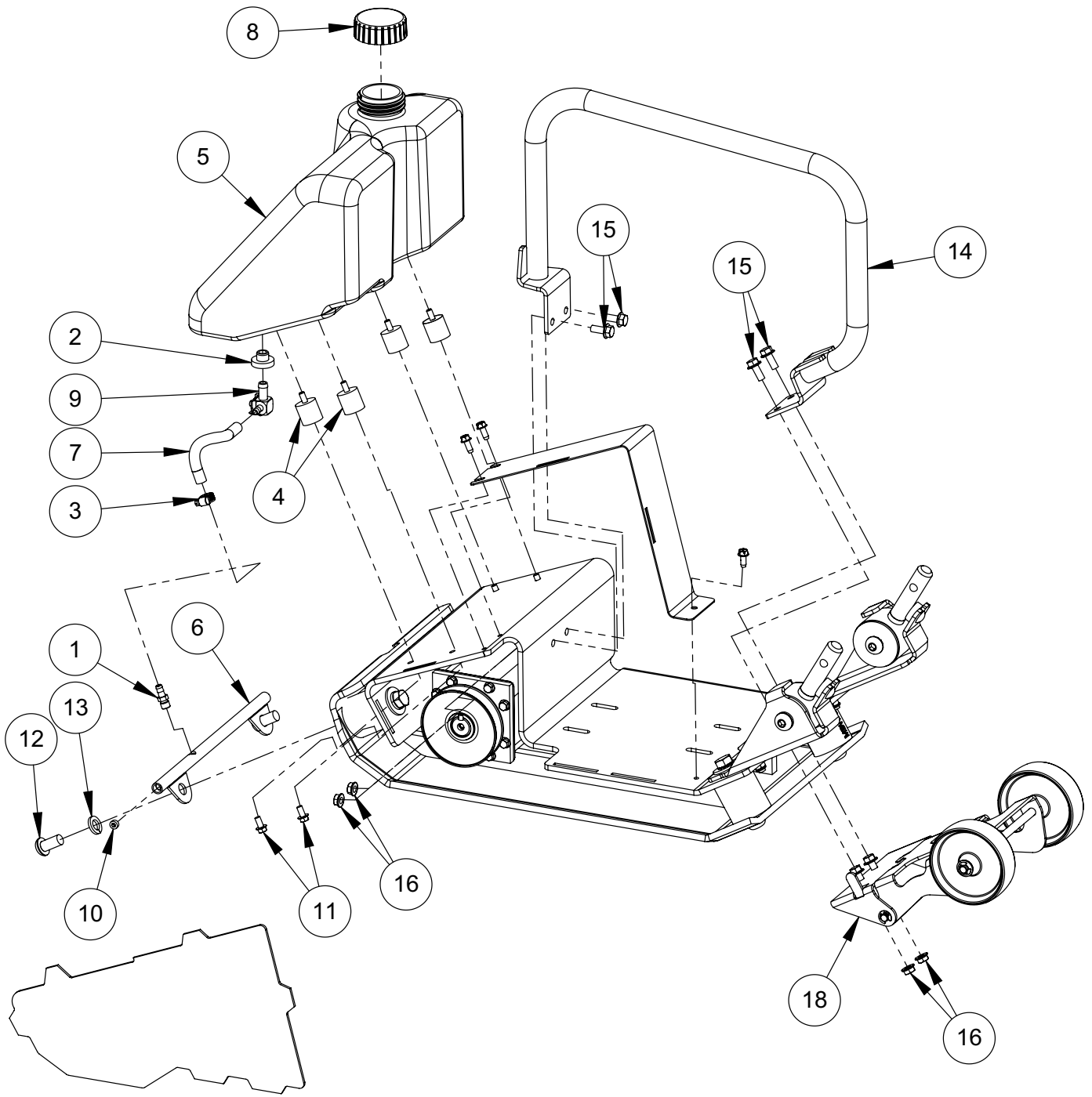

Optional Equipment

ITEM	PART NO.	DESCRIPTION	QTY
		WATER TANK	
1.	05803	PIPE ADAPTER, MALE	1
2.	06192	GROMMET, WATER TANK	1
3.	08442	CLAMP, WORM DRIVE	1
4.	17643	SHOCK MOUNT 1" DIA.	4
5.	20486	WATER TANK, GPX PLATE	1
6.	22261	SPRAY BAR, AP12	1
	22262	SPRAY BAR, AP15	1
	22263	SPRAY BAR, AP18	1
7.	20494	HOSE, 1/4" x 7" LG.Serial No. 1121834, 1160764 & 1181585 and below)	1
	22243	HOSE, 1/4" x 5" LG.Serial No. 1121835, 1160765 & 3180001 and above)	1
8.	20496	CAP, WATER TANK	1
9.	20497	VALVE, WATER TANK	1
10.	F0227SPP	SOCKET PIPE PLUG, 1/8-27	2
11.	F042004FWS	FLANGE HEAD SCREW, 1/4-20 x 1/2 LG.	4
12.	F081308BCS	BUTTON HEAD SCREW, 1/2-13 x 1" LG.	2
13.	F08LW	LOCK WASHER, 1/2" ZP	2
		LIFT CAGE	
14.	20797	LIFT CAGE	1
15.	F051807FWS	FLANGE HEAD SCREW, 5/16-18 x 7/8 LG.	4
16.	F0518FN	FLANGE LOCK NUT, 5/16-18	4
		WHEEL KIT:	
17.	19755	HANDLE BUMPERS	2
18.	20736	WHEEL KIT ASSEMBLY (includes items 15 & 16)	1
19.	F051804FWS	FLANGE HEAD SCREW, 5/16-18 x 1/2 LG.	2
		OPTION KITS:	
	20482	WATER TANK, AP12	
	20483	WATER TANK, AP15	
	20484	WATER TANK, AP18	
	20801	LIFT CAGE, 12 THRU 18	
	21050	PAVER PAD, GP12	
	21051	PAVER PAD, GP15	
	21052	PAVER PAD, GP18	

WARRANTY

1. IN GENERAL - The warranties described in this document are provided by M-B-W, INC. and MBW EUROPE, LTD. ("MBW") to define what is, what is not, and for how long machines and parts are covered against material defects and/or defective workmanship. To obtain warranty service, the purchaser must, within the Warranty Period (defined in Paragraph 3): (i) report the product defect to an authorized repair center, (ii) make a written request for repair, (iii) provide proof of purchase to the authorized repair center, and (iv) deliver the equipment to the authorized repair center. A list of authorized repair centers is available on the MBW website (mbw.com) or by contacting MBW at 800-678-5237.

2. COVERED - MBW's obligation under this limited warranty is limited to the cost of the parts and the labor to repair any defect in material and/or workmanship at an authorized MBW repair center. Transportation charges are not covered by this limited warranty.

3. WARRANTY PERIODS - The Warranty Period begins on, as applicable: (i) the product purchase date by an end user or (ii) the first day the product is put into rental or two years after invoice date from MBW to Dealer, whichever starts the warranty period first. To insure that your warranty is in place, fill out the warranty card and mail it in or register your product online at www.mbw.com/service-support/warranty-registration. The warranty is nontransferable.

The Warranty Period ends after:

- A. New Ground compaction equipment - 2 years.
 - B. New Concrete finishing equipment - 1 year.
 - C. New Utility equipment - 1 year.
 - D. Demonstration equipment - 6 months.
 - E. Wear parts: lubricants, filters, belts and shock mounts - 30 days.
4. NOT COVERED- This warranty does not include, and MBW specifically excluded from any warranty:
- A. Used equipment - all used equipment is not warranted and is sold 'as is' 'where is' with all defects.
 - B. Replacement electrical parts, including but not limited to: electric motors, circuit boards, switches, are not warranted or returnable.
 - C. OEM: engines, batteries, and chargers. Those warranties are covered by the manufacturer.
 - D. Consumable parts: trowel and screed blades.
 - E. Equipment that has been: altered, abused, neglected, not maintained, or modified to run outside its specifications. Any modification to the machine or its parts makes this warranty null and void.
 - F. Other: damage to a product from normal wear, air freight, overtime, pickup and delivery, temporary replacement rentals, freight damage, or other similar incidents.
 - G. Product used in a fashion it was not designed for.
 - H. Parts and labor not performed by authorized dealers.

It is at MBW's discretion if warranty applies and has the right to adjust labor rates on a claim by claim basis.

5. OTHER - IT IS EXPRESSLY AGREED THAT THIS SHALL BE THE SOLE AND EXCLUSIVE REMEDY UNDER THIS WARRANTY. UNDER NO CIRCUMSTANCES SHALL MBW BE LIABLE FOR ANY COSTS, LOSS, EXPENSE, DAMAGE, SPECIAL DAMAGES, DIRECT DAMAGES, INCIDENTAL DAMAGES, EXEMPLARY, CONSEQUENTIAL, OR PUNITIVE DAMAGES ARISING DIRECTLY OR INDIRECTLY FROM THE USE OF MBW PRODUCT OR DAMAGES FOR LOSS OF USE, LOSS OF ANTICIPATED PROFITS, INCOME, OR ECONOMIC LOSSES OF ANY KIND. MBW'S LIABILITY TO BUYER UNDER THESE WARRANTIES FOR THE PRODUCT IS LIMITED AS SET FORTH HEREIN, WHETHER BASED UPON WARRANTY, CONTRACT, NEGLIGENCE, TORT, STRICT LIABILITY OR ANY OTHER THEORY OF LIABILITY, INCLUDING BUT NOT LIMITED TO FRAUD, MISREPRESENTATION, BREACH OF CONTRACT, PERSONAL INJURY, PRODUCTS LIABILITY OR ANY OTHER THEORY.

MBW'S LIABILITY UNDER ANY WARRANTY HEREUNDER, WHETHER EXPRESS OR IMPLIED, SHALL NOT EXCEED THE COST OF REPAIR OR REPLACEMENT OF DEFECTIVE PARTS OF THE PRODUCT OR THE PRODUCT. BUYER MAY NOT BRING ANY ACTION UNDER THESE WARRANTIES MORE THAN ONE YEAR AFTER THE CAUSE OF ACTION HAS ACCRUED.

THE FORGOING WARRANTY IS EXPRESSED IN LIEU OF ALL OTHER WARRANTIES, EXPRESSED OR IMPLIED, INCLUDING THE WARRANTIES OF MERCHANTABILITY, FITNESS FOR USE, AND FITNESS FOR A PARTICULAR PURPOSE, AND ALL OTHER OBLIGATIONS OR LIABILITY ON MBW'S PART. MBW SPECIFICALLY DISCLAIMS AND EXCLUDES ANY AND ALL WARRANTIES OF MERCHANTABILITY AND FITNESS FOR A PARTICULAR PURPOSE.

MBW NEITHER ASSUMES NOR AUTHORIZES ANY OTHER PERSON TO ASSUME ON BEHALF OF MBW ANY OTHER LIABILITY OR WARRANTY IN CONNECTION WITH THE SALE OR SERVICE OF ANY MBW PRODUCT.

Some states do not allow limitations on how long an implied warranty lasts, so the above limitation may not apply to you. This warranty gives you specific legal rights, and you may also have other rights which vary from state to state.

NOTES:

NOTES:
