

OPERATOR'S SAFETY AND SERVICE MANUAL



2000, 2018 AP2000+ & 3550

This manual covers the following serial numbers
and higher for each model listed:

2000.....	2070150.
2018.....	2180195.
3550.....	3551200.



VIBRATORY PLATES

MBW, Inc.
250 Hartford Rd • PO Box 440
Slinger, WI 53086-0440
Phone: (262) 644-5234
Fax: (262) 644-5169
Email: mbw@mbw.com
Website: www.mbw.com

MBW Europe Ltd.
Units 2 & 3 Cochrane Street
Bolton BL3 6BN, England
Phone: +44 (0) 1204 387784
Fax: +44 (0) 1204 387797
Email: saleseurope@mbw.com
Website: www.mbweurope.com

L18702/ 01.22.AK
©MBW, Inc. 2015
Printed in the USA

TABLE OF CONTENTS

SAFETY INFORMATION	1	Service Tools	9
Introduction	1	Exciter Removal	9
Safety Precautions	1	(2000) Exciter Disassembly	9
SPECIFICATIONS	3	(2000) Exciter Assembly	10
OPERATION	5	(3550) Exciter Disassembly	10
Introduction	5	(3550) Exciter Assembly	10
Before Starting & Operating	5	Exciter installation	11
Starting Engine	5	Parts Replacement Cycles and Tolerances	11
Operating	5		
Stopping Engine	5	REPLACEMENT PARTS	13
Lifting/Transporting	5	2000 & 2018 EXCITER ASSEMBLY	14
MAINTENANCE	6	3550 Exciter Assembly	16
Maintenance Schedule	6	ENGINE ASSEMBLY 2000/2018	18
Fluid Levels	6	ENGINE ASSEMBLY 3550	20
Engine Maintenance	6	ROLLCAGE ASSEMBLY	22
Engine Speed	6	2018 ASSEMBLY	24
Cleaning Plate	6		
Belt Adjustment	6	WARRANTY	26
Checking Exciter Oil	7		
Changing Exciter Oil	7		
SERVICE	9		
Torque Chart	9		



WARNING



CALIFORNIA PROPOSITION 65 WARNING

Engine exhaust and some of its constituents and dust produced during the use of this product contain chemicals known in the state of California to cause cancer, birth defects, and other reproductive harm.

For more information go to **www.P65Warnings.ca.gov**

SAFETY INFORMATION

Introduction



This Safety Alert Symbol is used to call attention to items or operations which may be dangerous to those operating or working with this equipment.

The symbol can be found throughout this manual and on the unit. Please read these warnings and cautions, along with all decals, carefully before attempting to operate the unit. Make sure every individual who operates or works with this equipment is familiar with all safety precautions.

WARNING

GENERAL WARNING. Indicates information important to the proper operation of the equipment. Failure to observe may result in damage to the equipment and/or severe bodily injury or death.

CAUTION

GENERAL CAUTION. Indicates information important to the proper operation of the equipment. Failure to observe may result in damage to the equipment.

Safety Precautions



LETHAL EXHAUST GAS: An internal combustion engine discharges carbon monoxide, a poisonous, odorless, invisible gas. Death or serious illness may result if inhaled. Operate only in a properly ventilated area. **NEVER OPERATE IN A CONFINED AREA!**



DANGEROUS FUELS: Use extreme caution when storing, handling and using fuels as they are highly volatile and explosive in vapor state. Do not add fuel while engine is running. Stop and cool the engine before adding fuel. **DO NOT SMOKE!**



SAFETY GUARDS: It is the owner's responsibility to ensure that all guards and shields are in place and in working order.



IGNITION SYSTEMS: Breakerless, magneto, and battery ignition systems can cause severe electrical shocks. Avoid contacting these units or their wiring.



SAFE DRESS: Do not wear loose clothing, rings, wristwatches, etc. near machinery.



NOISE PROTECTION: Wear OSHA specified hearing protection devices.



EYE PROTECTION: Wear OSHA specified eye shields, safety glasses, and sweat bands.



FOOT PROTECTION: Wear OSHA specified steel-tipped safety shoes.

HEAD PROTECTION: Wear OSHA specified safety helmets.



OPERATOR: Keep children and bystanders off and away from the equipment.

DUST PROTECTION: Machining, crushing or handling of stone, concrete, masonry, metal and other materials may generate dust, mist and fumes containing chemicals such as silica

known to cause serious or fatal injury or illness such as respiratory disease, silicosis, cancer, birth defects, or other reproductive harm.

- Control dust, mist and fumes at the source where possible. Water should be used to control dust whenever feasible.
- Use good work practices and follow the recommendations of the manufacture, OSHA/NIOSH and other occupational trade associations.
- When hazards cannot be eliminated the operator and any bystanders should always wear a OSHA specified respirator for materials being handled.

REFERENCES: For details on safety rules and regulations in the United States, contact your local Occupational Safety and Health Administration (OSHA) office. Equipment operated in other countries must be operated and serviced in accordance and compliance with any and all safety requirements of that country. The publication of these safety precautions is done for your information. MBW does not by the publication of these precautions, imply or in any way represent that these are the sum of all dangers present near MBW equipment. If you are operating MBW equipment, it is your responsibility to insure that such operation is in full accordance with all applicable safety requirements and codes. All requirements of the United States Federal Occupational Safety and Health Administration Act must be met when operated in areas that are under the jurisdiction of that United States Department.

Safety Decals

Carefully read and follow all safety decals. Keep them in good condition. If decals become damaged, replace as required. If repainting the unit, replace all decals. Decals are available from authorized MBW distributors. Order the decal set listed on the following page.



21742



01066

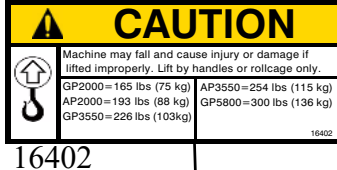

16402

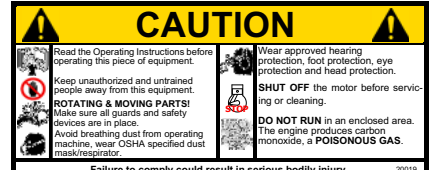

20019



22531



20526 - 2000
20527 - 3550

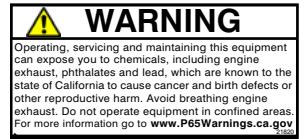
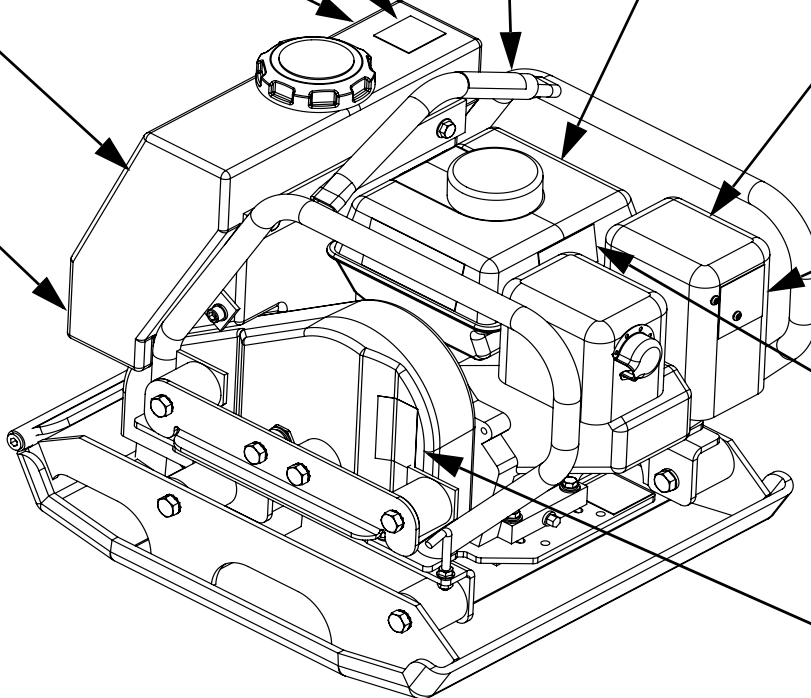

21820

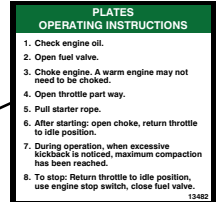

13482

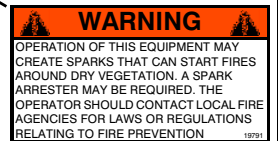

19791



21742

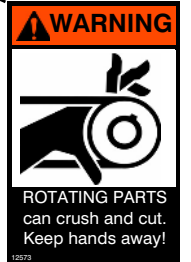

12573



22531



21059 - 2000
21060 - 3550

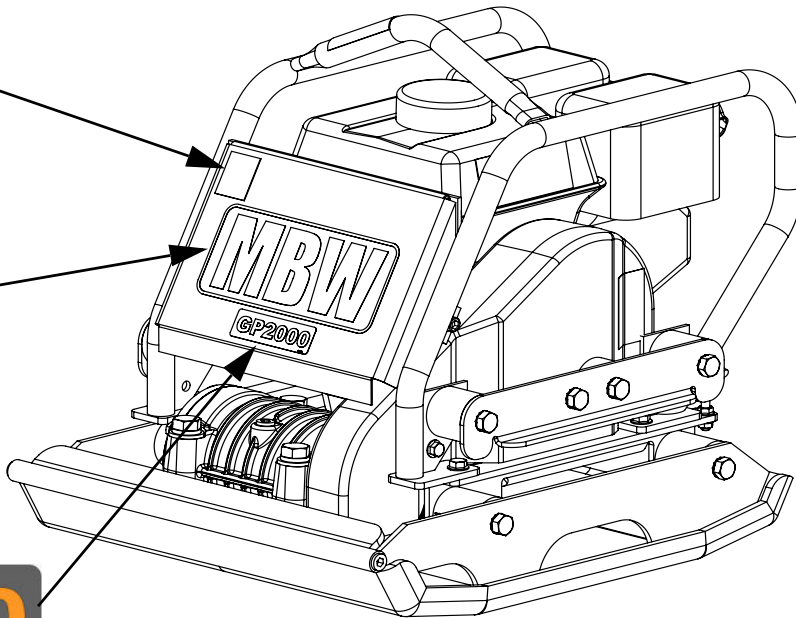

Safety Decals (Decal Set #12100)

SPECIFICATIONS

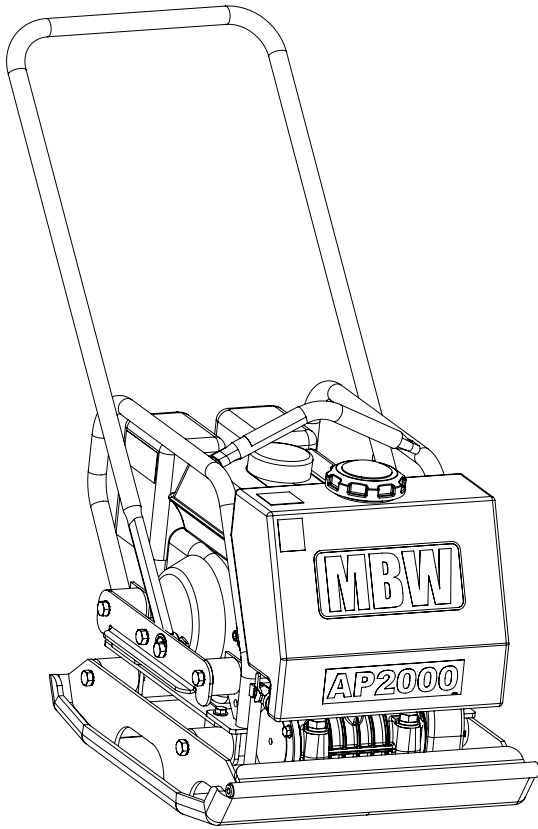

AP2000

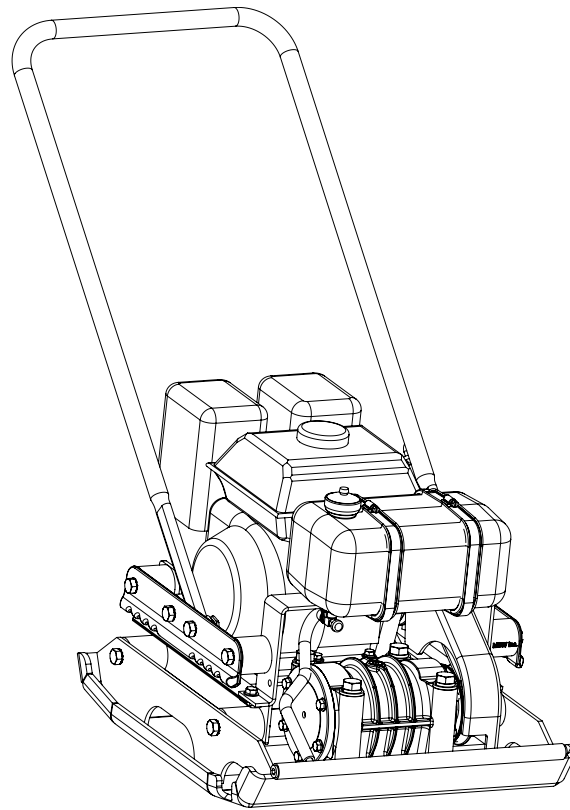

AP2018

	AP2000	GP2000	AP2018	GP2018
CENTRIFUGAL FORCE	2475 lbf (1123 kg)	3250 lbf (1474 kg)	2475 lbf (1123 kg)	3250 lbf (1474 kg)
EXCITER (VPM)	4400	5050	4400	5050
TRAVEL SPEED	90 ft/min(27 m/min)	120 ft/min(36 m/min)	90 ft/min(27 m/min)	120 ft/min(36 m/min)
COMPACTION DEPTH	12 in (30 cm)	14 in (36 cm)	12 in (30 cm)	14 in (36 cm)
WIDTH x LENGTH x HEIGHT	20 x 22 x 21 in (51 x 56 x 53 cm)	20 x 22 x 21 in (51 x 56 x 53 cm)	20 x 22 x 18 in (51 x 56 x 46 cm)	20 x 22 x 18 in (51 x 56 x 46 cm)
OPERATING WEIGHT (HONDA)	168 lbs (76 kg) no water 193 lbs (88 kg) full water	165 lbs (75 kg)	168 lbs (76 kg) no water 178 lbs (81 kg) full water	163 lbs (74 kg)
ENGINE SPEED	3400 (RPM)	3400 (RPM)	3400 (RPM)	3400 (RPM)
WATER TANK CAPACITY	3 gal (11.3 l)		1 gal (4)	
NOISE LEVEL	84 - 94 dBA	84 - 94 dBA	84 - 94 dBA	84 - 94 dBA
ENGINE OPTIONS	HONDA GX160 (163 cm) ³			

Specifications subject to change without notice.

- No universal method or formula has been accepted for determining "Compaction Force". All manufactures employ their own method or formula.

SPECIFICATIONS

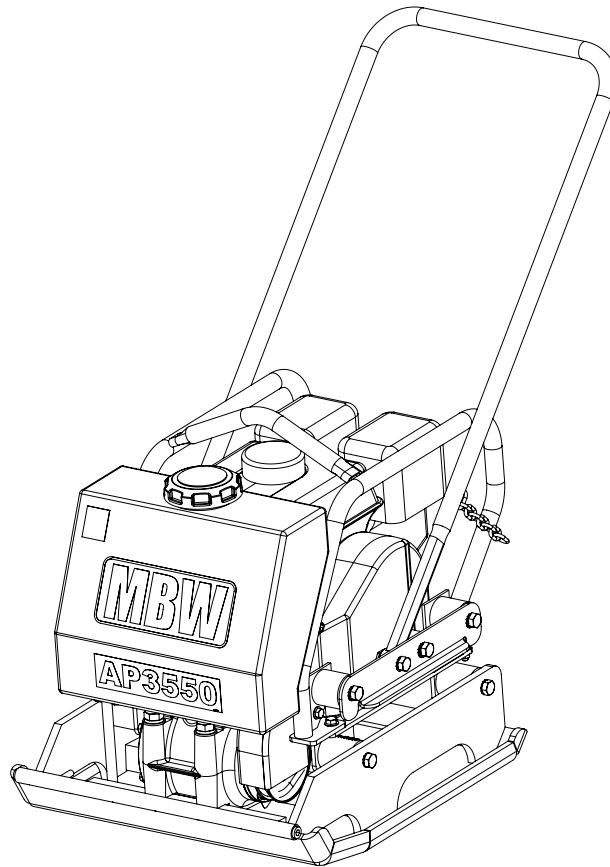

AP3550

	AP3550	GP3550
CENTRIFUGAL FORCE	3550 lbf (1610 kg)	3550 lbf (1610 kg)
EXCITER (VPM)	4400	4400
TRAVEL SPEED	110 ft/min(34 m/min)	110 ft/min(34 m/min)
COMPACTION DEPTH	18 in (46 cm)	18 in (46 cm)
WIDTH x LENGTH X HEIGHT	21 x 22 x 22.2 in (53 x 56 x 56.3 cm)	21 x 22 x 22.2 in (53 x 56 x 56.3 cm)
OPERATING WEIGHT (HONDA)	229 lbs (104 kg) no water 254 lbs (115 kg) full water	226 lbs (103 kg)
ENGINE SPEED	3400 (RPM)	3400 (RPM)
WATER TANK CAPACITY	3 gal (11.3 l)	
NOISE LEVEL	84 - 94 dBA	84 - 94 dBA
ENGINE OPTIONS	HONDA GX160 (163 cc) ³	

Specifications subject to change without notice.

- No universal method or formula has been accepted for determining "Compaction Force". All manufactures employ their own method or formula.

OPERATION

Introduction

MBW equipment is intended for use in very severe applications. They are powered by four cycle engines and are available in different sizes and a selection of engines.

This parts manual contains only standard parts. Variations of these parts as well as other special parts are not included. Contact your local MBW distributor for assistance in identifying parts not included in this manual.

Before Starting & Operating

- **HANDLE INSTALLATION** - Refer to ROLLAGE ASSEMBLY, page 22. Install handle by removing handle attachment nuts. Reinstall handle attachment nut through the handle bushings from the inside in. Make sure nylon bushings inside the handle stay in place.
- **REMEMBER!** It is the owner's responsibility to communicate information on the safe use and proper operation of this unit to the operators.
- Review ALL of the Safety Precautions listed on page 1 of this manual.
- Familiarize yourself with the operation of the machine and confirm that all controls function properly.
- Know how to STOP the machine in case of an emergency.
- Make sure hands, feet, and clothing are at a safe distance from any moving parts.
- **OIL LEVEL** - Check the oil level in the engine. For more information see "Lubrication" under the respective engine's "Owners Manual" or the Maintenance section of this manual.
- **AIR CLEANER** - Check to ensure element is in good condition and properly installed.
- **FUEL SUPPLY** - The engines on MBW equipment require an automotive grade of clean, fresh, unleaded gasoline.
- **FUEL FILTER** - If clogged or damaged, replace.

Starting Engine

1. Open fuel valve.
2. Turn engine switch to "ON".
3. Set throttle to idle.
4. Choke engine if necessary (you may not need to choke a warm engine).

5. Pull starter rope repeatedly until engine starts.
6. Move choke lever to open position.
7. Allow engine to warm up for one or two minutes.

Operating

1. Open throttle fully.
2. Compactor will begin vibrating and moving in a forward direction.
3. Maximum compaction of soil has been reached when excessive kickback is noticed in the compactor. The number of passes needed to reach compaction level desired will depend on soil type and moisture.
4. When using the compactor on asphalt use the water sprinkling system to keep the plate bottom from adhering to the hot asphalt.

Stopping Engine

1. Move throttle to idle position.
2. Let engine idle for one or two minutes.
3. Turn switch on engine to "STOP" position.
4. Turn off fuel valve.

Lifting/Transporting

1. The unit can be lifted by the handles on the sides of the unit or by the roll cage.
2. The unit must be transported in the upright position. DO NOT lay machine on its side or top.
3. Secure or tie down unit using the lift handles or roll cage.

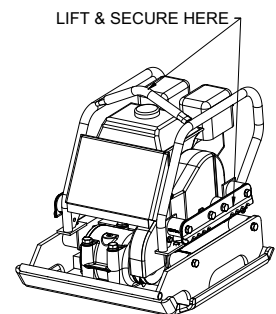

WARNING



Always stop the engine before:

Adding fuel.

Leaving the equipment unattended for any amount of time.

Before making any repairs or adjustments to the machine.

MAINTENANCE



WARNING



Always exercise the stopping procedure before servicing or lubricating the unit.

After servicing the unit, replace and fasten all guards, shields, and covers to their original positions before resuming operation.



CAUTION



Always verify fluid levels and check for leaks after changing fluids.

Do not drain oil onto ground, into open streams, or down sewage drains.

Maintenance Schedule

SYSTEM	MAINTENANCE	EACH USE	EVERY 50 HOURS	EVERY 250 HOURS	YEARLY
Engine	Refer to engine operator/owner manual	X			
Exciter	Check oil level		X		
	Check for oil leaks	X			
	Change oil			X	X
	Tighten Bolts ¹		X		X
Hardware	Check and tighten as needed ¹		X		X
Shock mounts	Check for cracks or tears		X		X

1. Check all hardware after the first 5 hours of use, then follow the maintenance schedule.

Fluid Levels

SYSTEM	FLUID VOLUME	RECOMMENDED OIL
Exciter	6 oz (2000 Plate) 8 oz. (3550 Plate)	MBW Ground Pounder® Exciter Oil ¹
Engine	Refer to engine operator/owner manual	

1. MBW #01058----- 6-Pack (8 oz. bottles)
MBW #17320----- 1 Quart (32 oz.)
MBW #20186-----1 Bottle (8 oz.)

Engine Maintenance

Refer to the engine Owner's Manual for maintenance intervals and procedures.

Engine Speed

1. Engine speed is factory set according to the speeds listed in the Specifications section of this manual. Do not tamper with the governor setting. The governor establishes safe operating limits which must not be exceeded.
2. Refer to the engine Owner's Manual for procedure on setting operating and idle speed.
3. The engine operating speed should be set to 3400 RPM.

4. The engine idle speed must not exceed 1800 rpm. If the idle speed is greater than 1800 RPM the clutch may not disengage.

Cleaning Plate

Remove any excess debris which may get into the housing of the unit.

Belt Adjustment

If any belt stretch develops follow these steps:
Reference engine assembly page.

1. Remove 4 flange bolts securing roll cage assembly to engine deck and remove roll cage assembly. See figure 1.

2. Apply moderate thumb pressure to belt about half way between pulleys. When properly adjusted the belt should deflect approximately 3/8" (9mm). If the belt is adjusted correctly reinstall belt guard and hardware.
3. To adjust belt tension loosen (do not remove) the (4) engine bolts.
4. Push engine towards the back of the plate. While holding pressure on the engine retighten the (4) engine bolts.
5. Recheck belt tension as described in step 2 and readjust if necessary until the proper tension is reached.
6. Reinstall roll cage assembly.

4. screws securing roll cage to engine deck. If machine is equipped with water tank disconnect hose from spray bar on front of plate. Now entire roll cage assembly, including roll cage, handle, water tank and belt guard, can be removed (see Figure 1).
5. Clean all dirt and debris from exciter to prevent contamination of exciter oil.
6. Remove pipe plug from top of exciter housing.
7. Rotate exciter shaft so a metal dip stick can be inserted into exciter (see Figure 2).
8. Place a clean metal rod through the oil fill hole as shown in figure 2.
9. Exciter should have approximately 3/4" (2000 plate) 7/8 to 1" (3550 plate) oil.
10. If oil need to be added, refer to Fluid Levels page of this section for type of oil to be used. DO NOT OVERFILL, over filling can cause excessive heat in exciter.
11. Apply pipe sealant to pipe plug and reinstall into top of exciter housing.
12. Reinstall roll cage assembly and re-attach hose to

Checking Exciter Oil

WARNING

Exciter and oil is hot after machine has been running. Allow machine to cool before servicing unit.

1. Let exciter cool before checking oil.
2. Place plate on a level surface.
3. Remove roll cage assembly by removing (4) flange

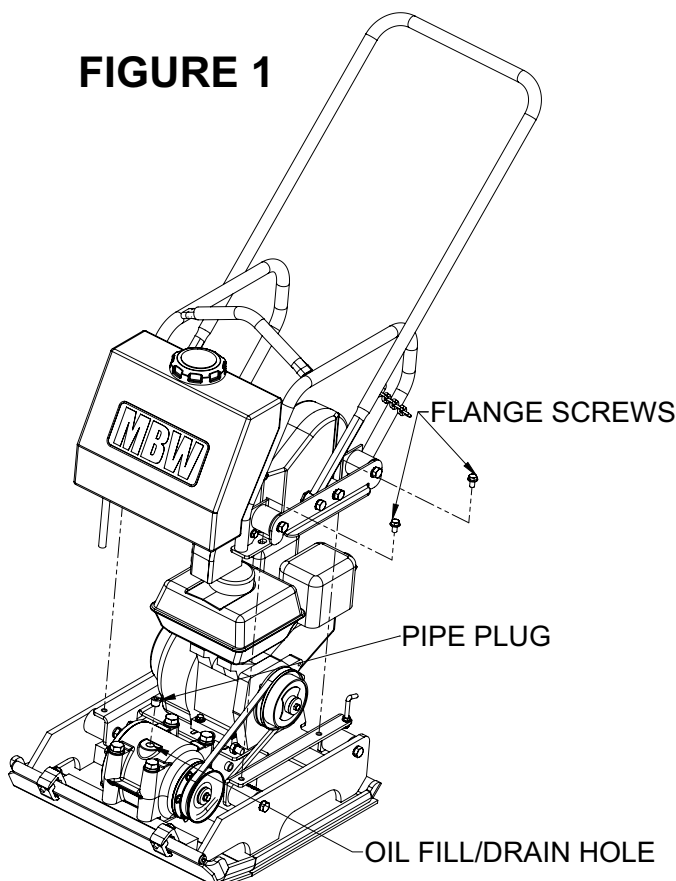
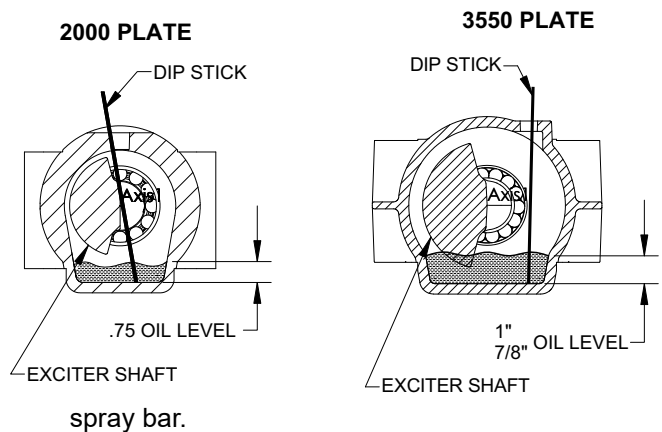

FIGURE 1

FIGURE 2



Changing Exciter Oil

WARNING

Exciter and oil is hot after machine has been running. Allow machine to cool before servicing unit.

1. Let exciter cool before changing oil.
2. Remove roll cage assembly by removing (4) flange screws securing roll cage to engine deck. If machine is equipped with water tank disconnect hose from spray bar on front of plate. Now entire roll cage assembly, including roll cage, handle, water tank and belt guard, can be removed (see Figure 1).

3. Remove 1/2" hex head cap screws and lock washers from side of bottom plate. Remove belt and engine deck assembly. Refer to figure 3
4. Clean all dirt and debris from exciter to prevent contamination of exciter oil.
5. Remove pipe plug from top of exciter housing. Rotate exciter shaft 90°, as shown in figure 2. Extract oil from bottom of exciter with a vacuum pump. If a vacuum pump is not available tilt plate housing upside down to drain oil from housing.
6. (Optional 3550 Only) Remove oil drain screw and brass washer from exciter rear cover. Tilt bottom plate housing on it's side to drain oil from housing. After draining oil, return bottom plate housing to the upright position and replace oil drain screw and brass washer.
7. Return plate housing to the upright position.
8. Fill exciter with MBW Ground Pounder® exciter oil to level specified in the Fluid Levels section of this manual.
9. Apply pipe sealant to pipe plug and reinstall into top of exciter housing.
10. Reinstall engine deck assembly, belt and roll cage assembly. If equipped with water tank reattach hose to spray bar.

FIGURE 3

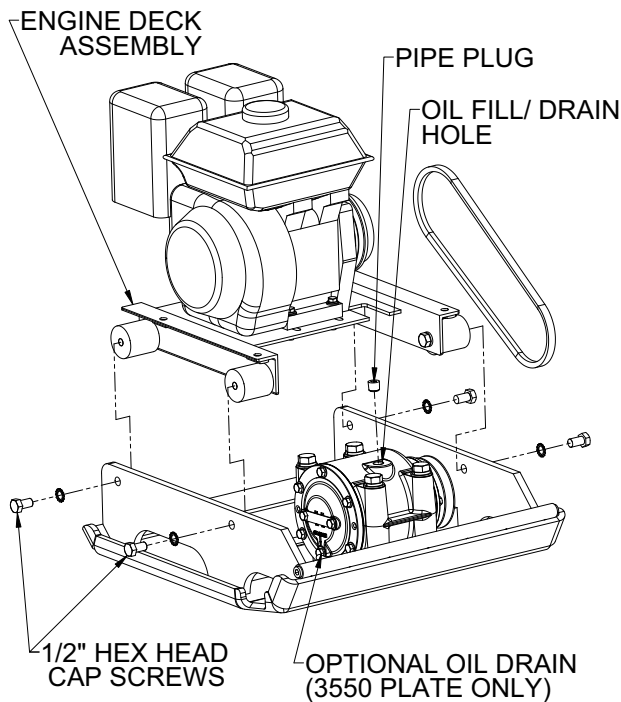

SERVICE

Assembly and disassembly should be performed by a service technician who has been factory trained on MBW equipment. The unit should be clean and free of debris.

Pressure washing before disassembly is recommended.

- Prior to assembly, wash all parts in a suitable cleaner or solvent.
- Check moving parts for wear and failure. Refer to the Replacement section in this manual for tolerance and replacement cycles.
- All shafts and housings should be oiled prior to pressing bearings. Also, ensure that the bearings are pressed square and are seated properly.
- All bearings should be replaced when rebuilding any exciter or gearbox.
- All gaskets and seals should be replaced after any disassembly.

Torque Chart

SIZE	GRADE 2	GRADE 5	GRADE 8
1/4-20	49 in·lbs	76 in·lbs	9 ft·lbs
1/4-28	56 in·lbs	87 in·lbs	10 ft·lbs
5/16-18	8 ft·lbs	13 ft·lbs	18 ft·lbs
5/16-24	9 ft·lbs	14 ft·lbs	20 ft·lbs
3/8-16	15 ft·lbs	23 ft·lbs	33 ft·lbs
3/8-24	17 ft·lbs	26 ft·lbs	37 ft·lbs
7/16-14	24 ft·lbs	37 ft·lbs	52 ft·lbs
7/16-20	27 ft·lbs	41 ft·lbs	58 ft·lbs
1/2-13	37 ft·lbs	57 ft·lbs	80 ft·lbs
1/2-20	41 ft·lbs	64 ft·lbs	90 ft·lbs
9/16-12	53 ft·lbs	82 ft·lbs	115 ft·lbs
5/8-11	73 ft·lbs	112 ft·lbs	159 ft·lbs
5/8-18	83 ft·lbs	112 ft·lbs	180 ft·lbs
3/4-16	144 ft·lbs	200 ft·lbs	315 ft·lbs
1-8	188 ft·lbs	483 ft·lbs	682 ft·lbs
1-14	210 ft·lbs	541 ft·lbs	764 ft·lbs
1-1/2-6	652 ft·lbs	1462 ft·lbs	2371 ft·lbs
M 6	3 ft·lbs	4 ft·lbs	7 ft·lbs
M 8	6 ft·lbs	10 ft·lbs	18 ft·lbs
M 10	10 ft·lbs	20 ft·lbs	30 ft·lbs
CONVERSIONS			
in·lbs x 0.083 = ft·lbs			
ft·lbs x 12 = in·lbs			
ft·lbs x 0.1383 = kg·m			
ft·lbs x 1.3558 = N·m			

Service Tools

Part No.	Description
17320	Ground Pounder® Exciter Oil
01629	Rubber Test Mat
12100	Decal Set

Exciter Removal

1. Remove roll cage assembly, engine deck assembly and belt. Refer to Changing Exciter Oil, page 7.
2. Remove (4) 5/8-11 exciter bolts, washers, lock washers and nuts. If unit has exciter shims (2) make note of location to assure proper placement during reassembling.
3. Clean exciter and drain oil as described in Changing Exciter Oil section of this manual before proceeding with disassembly.

(2000) Exciter Disassembly

Refer to 2000 & 2018 EXCITER ASSEMBLY, page 14. for exciter disassembly.

1. Remove flange screw (#22) and washer (#7) securing the pulley (17) to the exciter shaft (#18).
2. Slide pulley off of exciter shaft. be sure not to lose shaft key (#15).
3. Remove 6 flange screws (#22) from rear cover plate (#1) and remove cover, opposite of pulley end.
4. Support exciter assembly on outside diameter of exciter housing (#19) and press exciter shaft out of housing.
5. Remove 6 flange screws (#21) from front cover plate (#16) and remove front cover.

Note: If bearings have failed and need to be replace then proceed with bearing removal steps. If bearings do not need replacing skip to step #9.

6. Support exciter housing (#19) and press out front bearing (#3).
7. Remove front bearing (#3) inner race from exciter shaft by supporting O.D. of race and pressing exciter shaft thru.
8. Remove snap ring (#5) and press rear bearing (#4) off of shaft (#18).
9. When reassembling always replace, oil seal (#12) and front & rear cover gaskets (#9 & #10).

(2000) Exciter Assembly

Refer to 2000 & 2018 EXCITER ASSEMBLY, page 14. for exciter disassembly.

1. Prior to assembly, clean all parts in a suitable solvent or cleaning solution. When a complete disassembly is done it is recommended that all seals, gaskets and bearings are replaced.
- Note: If replacing bearings proceed to step #2, if not replacing bearings skip to step #6.**
2. Press front bearing (#3) inner race onto exciter shaft, pulley end.
3. Press front bearing (#3) into exciter housing (#19).
4. Press rear bearing (#4) onto exciter shaft, opposite pulley end, use care to press on I.D. of bearing only.
5. Install snap ring (#5) onto exciter shaft.
6. Press exciter shaft assembly into exciter housing (#19). Use care to properly support O.D. of housing and guide shaft into bearing already in housing.
7. Press oil seal (#12) into front cover (#16), seal to be press in until bottoming out on inside flange of front cover.
8. Install new gasket (#9), front cover (#16) and 6 flange screws (#21). Torque flange screws to 13 ft.-lbs.
9. Install new gasket (#10), rear cover (#1) and 6 flange screws (#22). Torque flange screws to 13 ft.-lbs.
10. Grease oil lip seal (#12) and exciter shaft. Install key (#15) on exciter shaft and slide pulley (#17) onto shaft.
11. Install washer (#7) and flange screw (#22), torque flange screw to 13 ft.-lbs.
12. Fill exciter with MBW Ground Pounder® exciter oil to level specified in the Fluid Levels section of this manual.

(3550) Exciter Disassembly

Refer to 3550 Exciter Assembly, page 16. for exciter disassembly.

1. Remove flange screw (#24) and washer (#10) securing the pulley (#19) to the exciter shaft (#20).
2. Slide pulley off of exciter shaft. be sure not to lose shaft key (#17).

Note: To aid in removal of rear cover you will need two 5/16-18 bolts, minimum grade 5.

3. Remove 6 flange screws (#24) from rear cover plate (#2). To press rear cover (#2) off of housing, thread two 5/16-18 grade 5 bolts into thread holes on cover. Turn bolts in with wrench or ratchet to press cover out. When pressing cover off try to keep even pressure on both side to ensure cover comes out straight.

4. Support exciter assembly on outside diameter of exciter housing (#1) and press exciter shaft out of housing.
5. Remove 6 flange screws (#23) from front cover plate (#18) and remove front cover.
Note: If bearings have failed and need to be replace then proceed with bearing removal step 6. If bearings do not need replacing skip to step #9.
6. Support exciter housing (#1) and press out front bearing (#8) from inside out.
7. Remove retainer plate (#3) by removing 2 cap screws (#22).
8. Remove snap ring (#6).
9. Remove bearing (#7) from rear cover (#2) with 1/4" punch. Tap the bearing out thru the holes for caps screws (#22). Be sure to alternate between holes to avoid cocking the bearing.
10. Remove snap ring (#5).
11. Remove bearing (#7) inner race from exciter shaft by supporting O.D. of race and pressing exciter shaft thru.
12. When reassembling always replace sealing washer (#25), oil seal (#13) and front & rear cover gaskets (#11 & #12).

(3550) Exciter Assembly

Refer to 3550 Exciter Assembly, page 16. for exciter assembly.

1. Prior to assembly, clean all parts in a suitable solvent or cleaning solution. When a complete disassembly is done it is recommended that all seals, gaskets and bearings are replaced.
- Note: If replacing bearings proceed to step #2, if not replacing bearings skip to step #6.**
2. Press front bearing (#8) into exciter housing (#1).
3. Press bearing (#7) inner race onto exciter shaft (#20).
4. Install snap ring (#5) onto exciter shaft.
5. Support I.D. and O.D. of bearing (#8) and press exciter shaft into bearing.
6. Check felt filter (#9) to be sure it is not blocked or deteriorating, Replace if damaged.

FIGURE 4

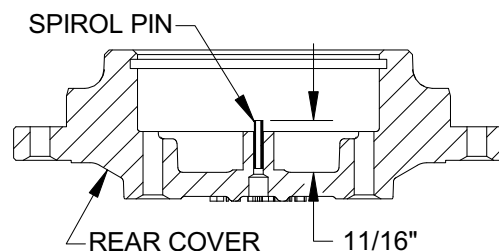

7. Check and set end of spirol pin (#21) to be 11/16" from inside of rear cover (#2). **See Figure 4.**

8. Press bearing (#7) into rear cover (#2) and install snap ring (#6) and gasket (#12).

Note: To aid in assembly of rear cover you will need three, 5/16-18 x 2-1/2 minimum length bolts, to aid in alignment of rear cover.

9. Apply oil to I.D. of exciter housing and O.D. of rear cover.

10. Set rear cover (#2) and new gasket (#12) on exciter housing and install three alignment bolts into exciter housing.

 **CAUTION** 

Be sure that the inner bearing race is properly aligned to slide into the bearing. If proper alignment is not maintained the shaft may push the front bearing out of the housing.

11. Carefully press or tap the rear cover (#2) down to seat on the exciter housing. Use care to keep cover straight when installing to prevent damaging housing or cover.

12. Remove the three alignment bolts and install six flange screws (#24) securing the rear cover. Torque flange screws to 13 ft.-lbs.

13. Use medium strength thread lock when installing retainer plate (#3) with 2 cap screws (#22).

14. Install oil drain cap screw (#22) and brass washer (#25).

15. Press oil seal (#13) into front cover (#18), Seal to be press in until flush with front cover.

16. Install new gasket (#11), front cover (#18) and 6 flange screws (#23). Torque flange screws to 13 ft.-lbs.

17. Install new gasket (#12), rear cover (#2) and 6 flange screws (#24). Torque flange screws to 13 ft.-lbs.

18. Grease oil lip seal (#13) and exciter shaft. Install key (#17) on exciter shaft and slide pulley (#19) onto shaft.

19. Install washer (#10) and flange screw (#24), torque flange screw to 13 ft.-lbs.

20. Fill exciter with MBW Ground Pounder® exciter oil to level specified in the Fluid Levels section of this manual.

Exciter installation

Refer to exciter assembly pages for each unit.

1. Clean exciter mounting bars on bottom plate. If unit was equipped with exciter shims (2 OR 4) replace to original position and set exciter assembly in place on mounting bars.

2. Check to make sure exciter sits flat on mounting bars, if not shim as needed.

3. Install (4) 5/8-11 exciter bolts, washers, lock washers, and 5/8-11 nuts. Torque exciter bolts to 150 ft.-lbs.

4. Reinstall engine deck, belt and roll cage assembly. If equipped with water tank reattach hose to spray bar. Adjust belt as describer in Belt Adjustment section of this manual.

Parts Replacement Cycles and Tolerances

Bearings	Replace anytime a bearing is rough, binding, discolored or removed from housing or shaft.
Clutch	Replace clutch if it does not disengage below 1800 rpm.
Engine Components	Refer to your engine manufacturer's Owner's Manual.
Hardware	Replace any worn or damaged hardware as needed. Replacement hardware should be grade 5 and zinc plated unless otherwise specified.
Safety Decals	Replace if they become damaged or illegible.
Seals & Gaskets	Replace if a leak is detected and at every overhaul or tear down.
V-Belts	Replace if cracked, torn, or stretched to the point the belt won't tension properly.
Exciter Oil	Replace once every season or every 250 hours. Use 6 oz. (2000 plate), 8 oz. (3550 plate) Ground Pounder® exciter oil.

This page intentionally left blank.

REPLACEMENT PARTS

The warranty is stated in this book on page 26. Failure to return the Warranty Registration Card renders the warranty null and void.

MBW has established a network of reputable distributors/dealers with trained mechanics and full facilities for maintenance and rebuilding, and to carry an adequate parts stock in all areas of the country. Their sales engineers are available for professional consultation. If you cannot locate an MBW distributor in your area, contact MBW or one of our Sales Branches listed below.

When ordering replacement parts, be sure to have the following information available:

- Model and Serial Number of machine when ordering MBW parts
- Model and Serial Number of engine when ordering engine parts
- Part Number, Description, and Quantity
- Company Name, Address, Zip Code, and Purchase Order Number
- Preferred method of shipping

REMEMBER - You own the best! If repairs are needed, use only MBW parts purchased from authorized MBW distributors.

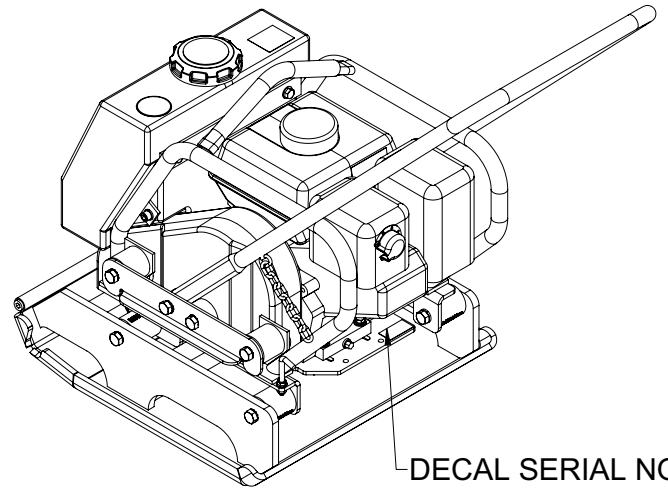

The unit's serial number can be found in the following locations:

- The model/serial number decal is located on the deck behind the engine.

Write Model Number here

Write Serial Number here

Contact Information

MBW, Inc.

250 Hartford Rd • PO Box 440
Slinger, WI 53086-0440
Phone: (262) 644-5234
Fax: (262) 644-5169
Email: mbw@mbw.com
Website: www.mbw.com

MBW Europe Ltd.

Units 2 & 3 Cochrane Street
Bolton BL3 6BN, England
Phone: +44 (0) 1204 387784
Fax: +44 (0) 1204 387797
Email: saleseurope@mbw.com
Website: www.mbweurope.com

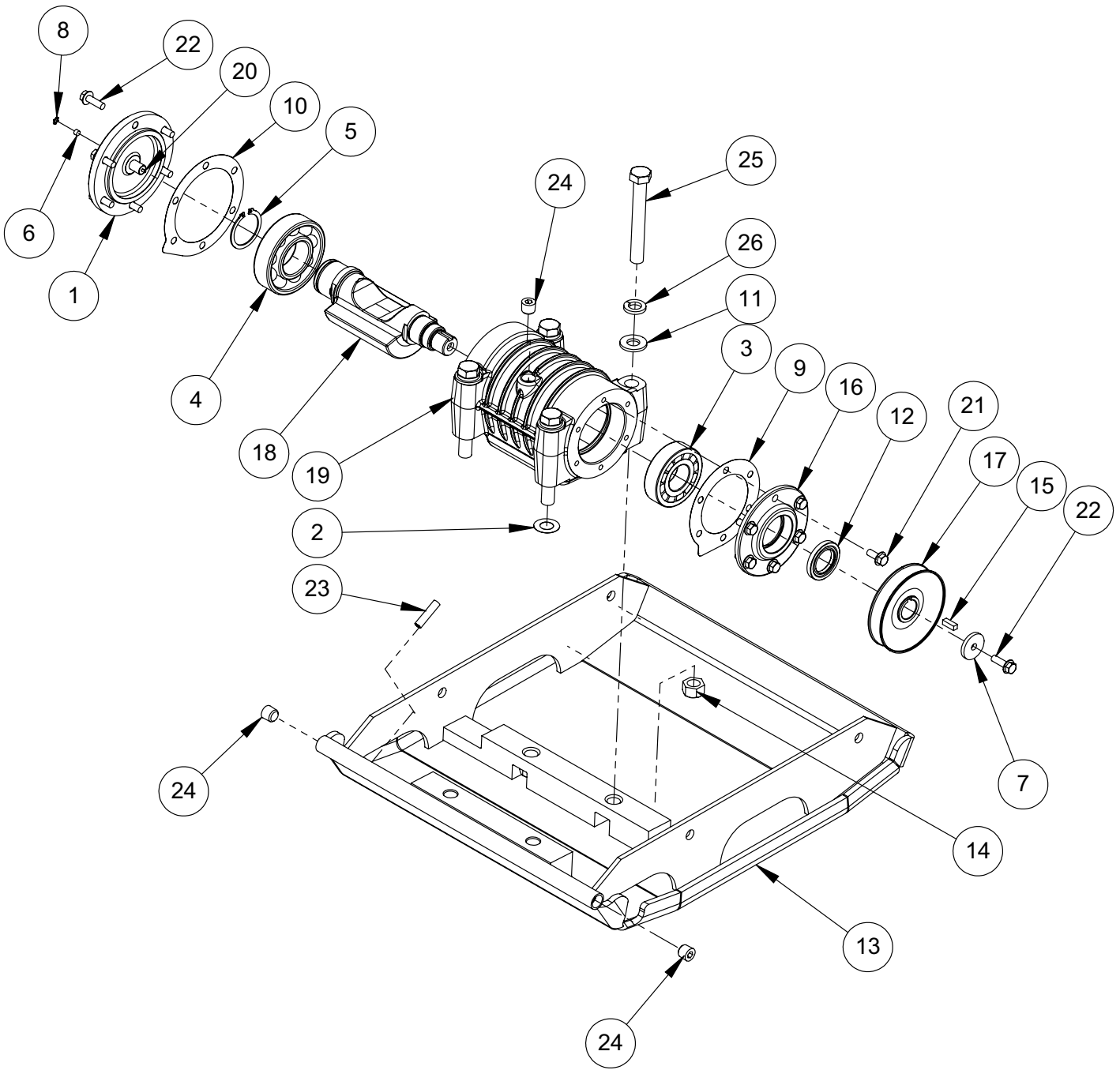

2000 & 2018 EXCITER ASSEMBLY

ITEM	PART NO.	DESCRIPTION	QTY
1.	00206	REAR COVER	1
2.	00259	SHIM, EXCITER (AS REQUIRED)	
3.	01004	CYLINDRICAL ROLLER BEARING	1
4.	01070	BALL BEARING	1
5.	01071	RETAINING RING, EXTERNAL	1
6.	01072	FILTER, FELT	1
7.	01099	WASHER	1
8.	01191	RETAINING RING, INTERNAL	1
9.	06096	GASKET	1
10.	06097	GASKET	1
11.	13451	WASHER, 5/8, A325, STRUCTURAL	4
12.	17179	OIL SEAL	1
	01002	OIL SEAL, SERIAL NO. 2064574 & LOWER	
13.	18697	BASEPLATE	1
14.	18701	HEX NUT, 5/8-11, GRADE 8	4
15.	19135	KEY, 1/4" SQ. X 3/4 SQUARE ENDS	1
	01283	KEY, 1/4" SQ. X 1-1/4 ROUND ENDS, SERIAL NO. 2064574 & LOWER	
16.	19628	FRONT COVER	1
	00005	FRONT COVER, SERIAL NO. 2064574 & LOWER	
17.	19629	PULLEY, 4-3/8 DIA x 1.0 I.D., AP2000 (ASPHALT VERSION)	1
	19630	PULLEY, 3-7/8 DIA x 1.0 I.D., GP2000 (SOIL VERSION & AP2000+)	1
	00003	PULLEY, 4-3/8 DIA x 1-1/8 I.D., AP2000 (ASPHALT PLATE) SER. NO. 2064574 & LOWER	
18.	00348	PULLEY, 3-7/8 DIA x 1-1/8 I.D., GP2000 (SOIL & 2000+ PLATE) SER. NO. 2064574 & LOWER	
	19835	EXCITER SHAFT	1
	00202	EXCITER SHAFT, SERIAL NO. 2064574 AND LOWER	
19.	20944	EXCITER HOUSING	1
20.	F0205SP	SPIROL PIN, 1/8 X 5/8 LG.	1
21.	F051806FWS	FLANGE LOCKING SCREW, 5/16-18 X 3/4 LG.	6
22.	F051808FWS	FLANGE LOCKING SCREW, 5/16-18 X 1 LG	7
23.	F0612SP	PIN, SPIROL	1
24.	F0618SPP	SOCKET PIPE PLUG, 3/8-18	3
25.	21099	HEX HEAD CAP SCREW, 5/8-11 x 4-3/4 LG, GRADE 8	4
	18696	HHCS, 5/8-11 X 5-3/4, GRADE 8,; SERIAL NO. 2070149/2180195 AND LOWER	4
26.	F10LW	LOCKWASHER, 5/8, ZP	4
		<u>SERVICE PARTS:</u>	
	00062	WASHER SEAL, PULLEY (NOT SHOWN) SERIAL NO. 2064574 AND LOWER	
		<u>REPLACEMENT KIT:</u>	
	19836	EXCITER ASSEMBLY (DOES NOT INCLUDE ITEMS 7, 15, 17 & 22)	
	18757	BOTTOM PLATE, AP/GP2000 (INCLUDES ITEMS: 2, 11, 14, 23 thru 26)	

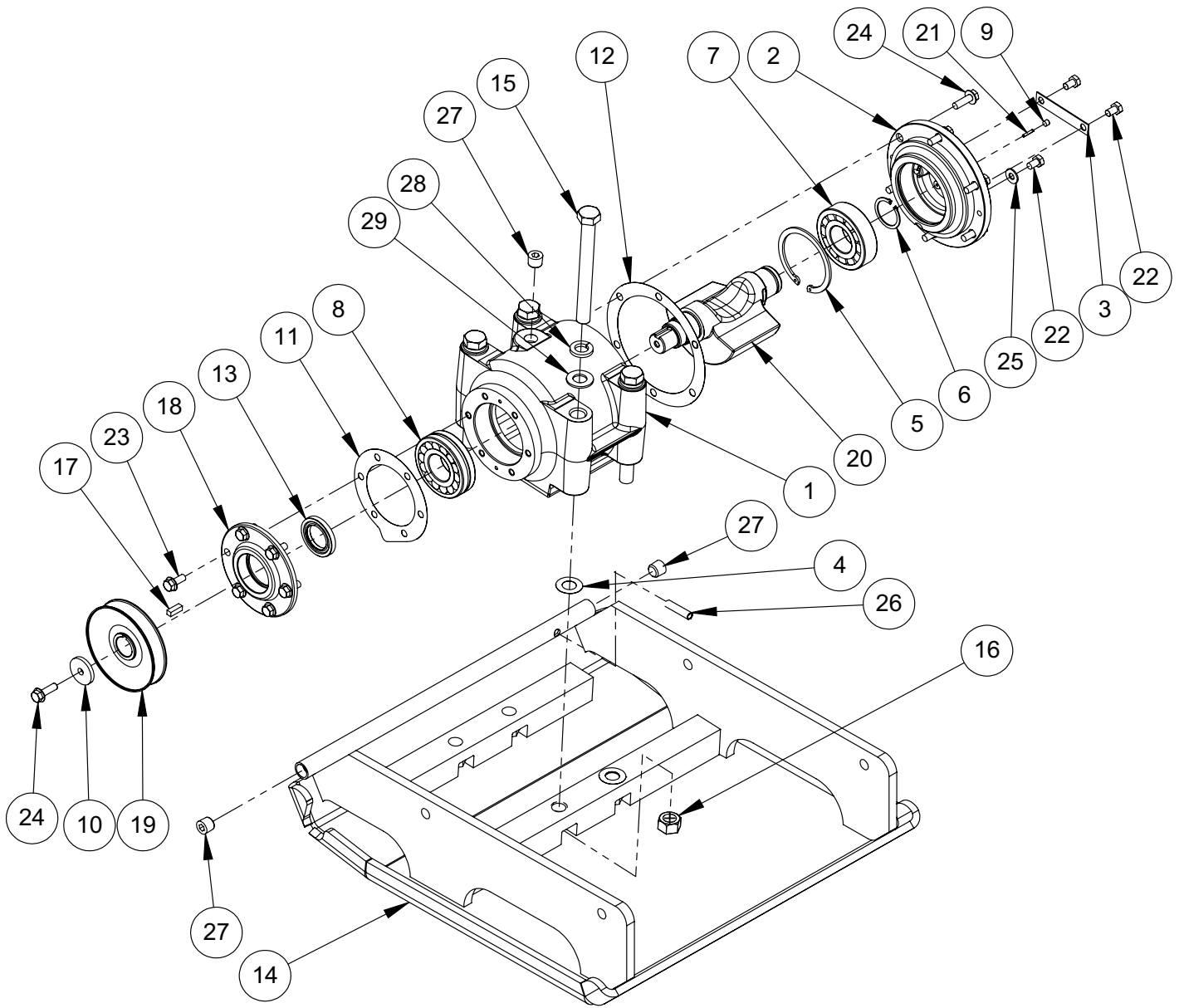

3550 Exciter Assembly

ITEM	PART NO.	DESCRIPTION	QTY
1.	00001	EXCITER HOUSING	1
2.	00006	REAR COVER	1
3.	00066	RETAINER PLATE	1
4.	00259	SHIM EXCITER (AS REQUIRED)	
5.	01000	RETAINING RING, INTERNAL	1
6.	01001	RETAINING RING, EXTERNAL	1
7.	01004	CYLINDRICAL ROLLER BEARING	1
8.	01005	SPHERICAL ROLLER BEARING	1
9.	01072	FILTER, FELT	1
10.	01099	WASHER	1
11.	06096	GASKET	1
12.	06098	GASKET	1
13.	17179	OIL SEAL	1
	01002	OIL SEAL, SERIAL NO. 3551199 & LOWER	
14.	18577	BASE PLATE	1
15.	18700	HHCS, 5/8-11 X 6 GRADE 8	4
16.	18701	HEX NUT, 5/8-11, GRADE 8 ZP	4
17.	19135	KEY, 1/4" SQ. X 3/4 SQUARE ENDS	1
	01283	KEY, 1/4" SQ. X 1-1/4 ROUND ENDS, SERIAL NO. 3551199 & LOWER	
18.	19628	FRONT COVER	1
	00005	FRONT COVER, SERIAL NO. 3551199 & LOWER	
19.	19629	PULLEY, EXCITER 4-3/8 DIA x 1.0 I.D.	1
	00003	PULLEY, 4-3/8 DIA x 1-1/8 I.D., SERIAL NO. 3551199 & LOWER	
20.	19912	EXCITER SHAFT	1
	18692	EXCITER SHAFT, SERIAL NO. 3551199 & LOWER	
21.	F0205SP	SPIROL PIN, 1/8 X 5/8 LG.	1
22.	F051804HCS	HEX HEAD CAP SCREW, 5/16-18 X 1/2LG.	3
23.	F051806FWS	FLANGE LOCKING SCREW, 5/16-18 X 3/4 LG.	6
24.	F051808FWS	FLANGE LOCKING SCREW, 5/16-18 X 1 LG	7
25.	F05BFW	WASHER, BRASS, 5/16	1
26.	F0612SP	SPIROL PIN	1
27.	F0618SPP	SOCKET PIPE PLUG, 3/8-18	3
28.	F10LW	LOCKWASHER, 5/8	4
29.	F10PW	WASHER, 5/8	4
		SERVICE PARTS:	
	00062	WASHER SEAL, PULLEY (NOT SHOWN) SERIAL NO. 2064574 & LOWER	
		REPLACEMENT KIT	
	19913	EXCITER ASSEMBLY (COMPLETE)	
	18758	BOTTOM PLATE	

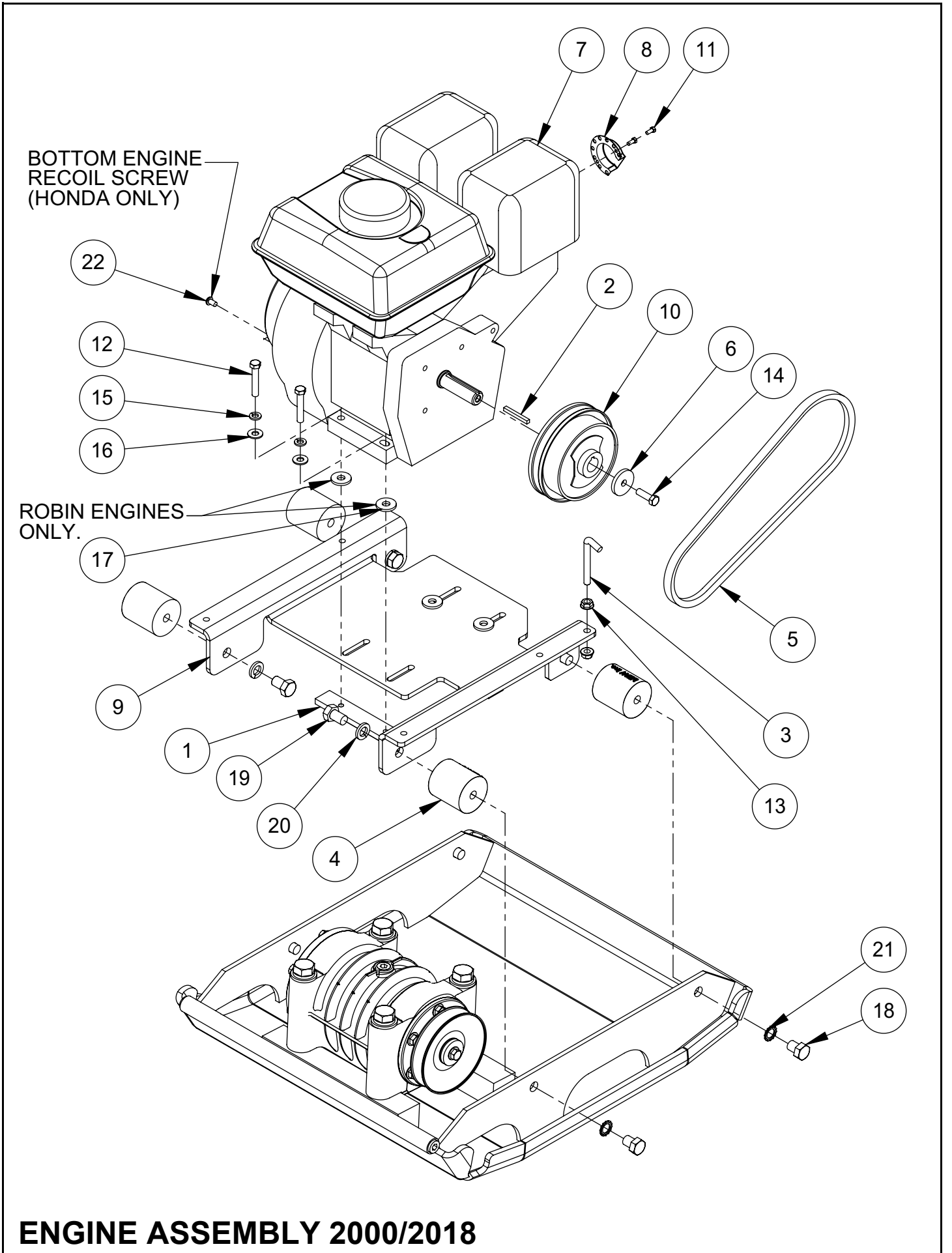

ITEM	PART NO.	DESCRIPTION	2000H	2018H
1.	00031	MOUNTING BAR, ENGINE	2	2
2.	00032	SHAFT KEY, 3/16" SQUARE x 1-5/8 LG.	1	1
3.	00048	HOOK BOLT, 5/16-18	1	1
4.	01011	SHOCK MOUNT	4	4
5.	01013	V-BELT A-30	1	1
6.	01099	WASHER	1	1
7.	01444	ENGINE HONDA, GX160	1	1
8.	07636	DEFLECTOR, EXHAUST, (HONDA)	1	1
9.	19531 19447	ENGINE DECK ENGINE DECK	1	1
10.	16105	CLUTCH, CENTRIFUGAL	1	1
11.	F0203HTB	SCREW, #8 x 3/8" LG. TYPE A, WASHER HEAD	2	2
12.	F051814HCS	HHCS, 5/16-18 x 1-3/4 LG. GRADE 5	4	4
13.	F0518FN	NUT, FLANGE WHIZ-LOCK, 5/16-18, ZP	2	2
14.	F052408HCS	HHCS, 5/16-24 X 1 LG. ZP	1	1
15.	F05LW	LOCKWASHER, 5/16, ZP	4	4
16.	F05SW	WASHER, 5/16, ZP	4	4
17.	F06SW	WASHER, 3/8, ZP		
18.	F081305HCS	HHCS, 1/2-13 x 5/8 LG. GRADE 5, ZP	4	4
19.	F081306HCS	HHCS, 1/2-13 x 3/4 LG. GRADE 5, ZP	4	4
20.	F08LW	LOCKWASHER, 1/2, ZP	4	4
21.	M12ETLW	LOCKWASHER, M12, EXTERNAL TOOTH	4	4
22.	M06C010BCS	BUTTON HEAD SCREW, M6 x 10mm	1	1
	20185	<u>KITS:</u> SERVICE KIT, HONDA 2000 PLATE, INCLUDES:		
		(4) #01011 SHOCK MOUNT		
		(4) #17170 SHOCK MOUNT		
		(1) #01013 V-BELT		
		(1) #19951 1-QUART OIL, 10W30 OIL		
		(1) #20186 oz. BOTTLE EXCITER OIL		
		(1) #Q17210ZE1822 AIR CLEANER ELEMENT		
		(1) #Q9807956846 SPARK PLUG		

BOTTOM ENGINE
RECOIL SCREW
(HONDA ONLY)

ROBIN ENGINE
ONLY

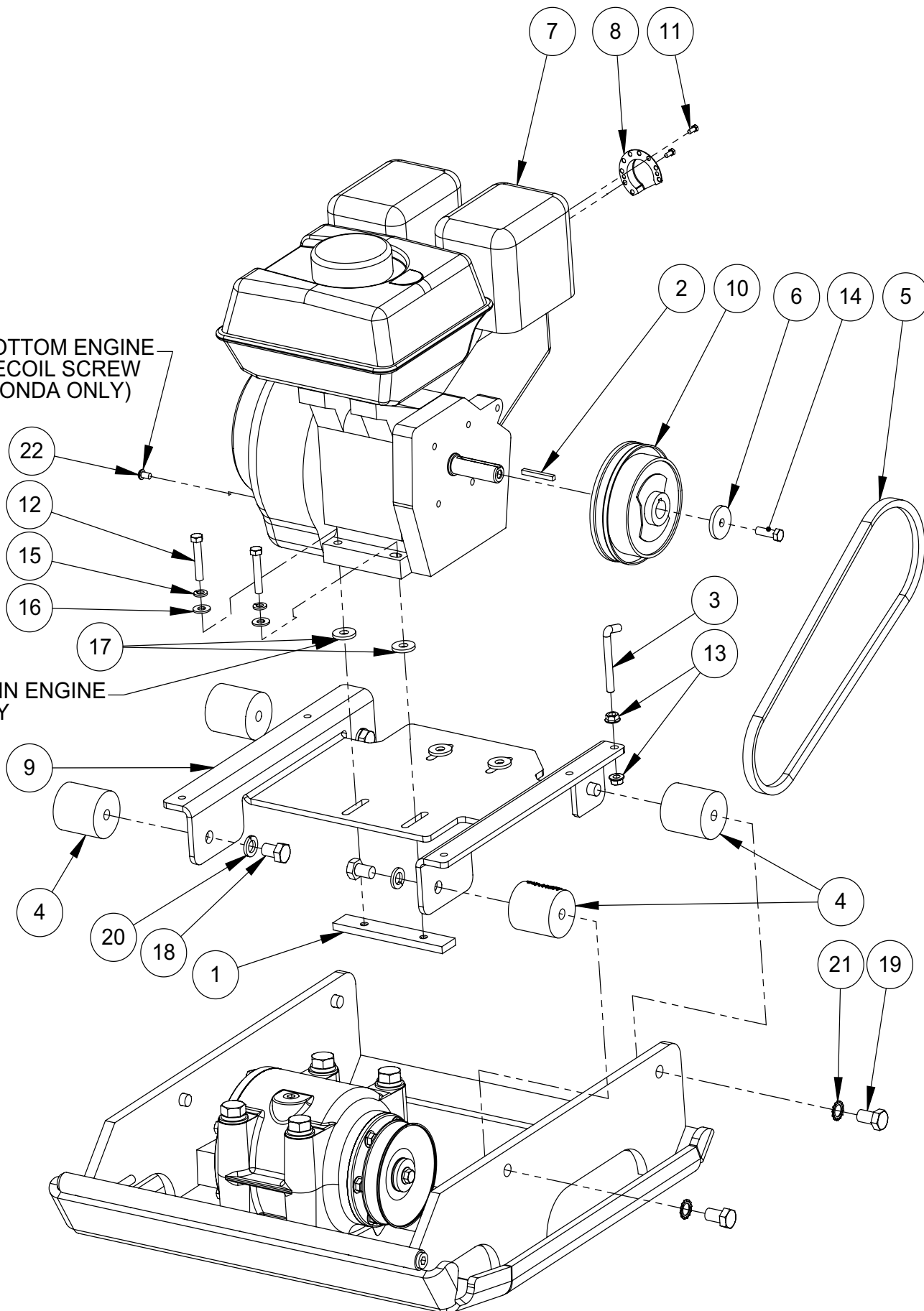

ENGINE ASSEMBLY 3550

ITEM	PART NO.	DESCRIPTION	3550H
1.	00031	MOUNTING BAR, ENGINE	2
2.	00032	SHAFT KEY, 3/16" SQUARE x 1-5/8 LG.	1
3.	00048	HOOK BOLT, 5/16-18	1
4.	01011	SHOCK MOUNT	4
5.	07288	V-BELT A-32, (SERIAL NO 35500759 & BELOW)	1
	06931	V-BELT A-31, (SERIAL NO 35500760 & UP)	1
6.	01099	WASHER	1
7.	01444	ENGINE HONDA, GX160	1
8.	07636	DEFLECTOR, EXHAUST, (HONDA)	1
9.	19531	ENGINE DECK	1
10.	16105	CLUTCH, CENTRIFUGAL	1
11.	F0203HTB	SCREW, #8 x 3/8" LG. TYPE A, WASHER HEAD	2
12.	F051814HCS	HHCS, 5/16-18 x 1-3/4 LG. GRADE 5	4
13.	F0518FN	NUT, FLANGE WHIZ-LOCK, 5/16-18, ZP	2
14.	F052408HCS	HHCS, 5/16-18 X 1 LG. ZP	1
15.	F05LW	LOCKWASHER, 5/16, ZP	4
16.	F05SW	WASHER, 5/16, ZP	4
17.	F06SW	WASHER, 3/8, ZP	4
18.	F081306HCS	HHCS, 1/2-13 x 3/4 LG. GRADE 5, ZP	4
19.	F081307HCS	HHCS, 1/2-13 x 7/8 LG. GRADE 5, ZP	4
20.	F08LW	LOCKWASHER, 1/2, ZP	4
21.	M12ETLW	LOCKWASHER, M12, EXTERNAL TOOTH	4
22.	M06C010BCS	BUTTON HEAD SCREW, M6 x 10mm	1
	20188	<u>KITS:</u> SERVICE KIT, HONDA 3550 PLATE, INCLUDES:	
		(4) #01011 SHOCK MOUNT	
		(4) #17170 SHOCK MOUNT	
		(1) #06931 V-BELT	
		(1) #19951 1-QUART OIL, 10W30 OIL	
		(1) #20186 oz. BOTTLE EXCITER OIL	
		(1) #Q17210ZE1822 AIR CLEANER ELEMENT	
		(1) #Q9807956846 SPARK PLUG	

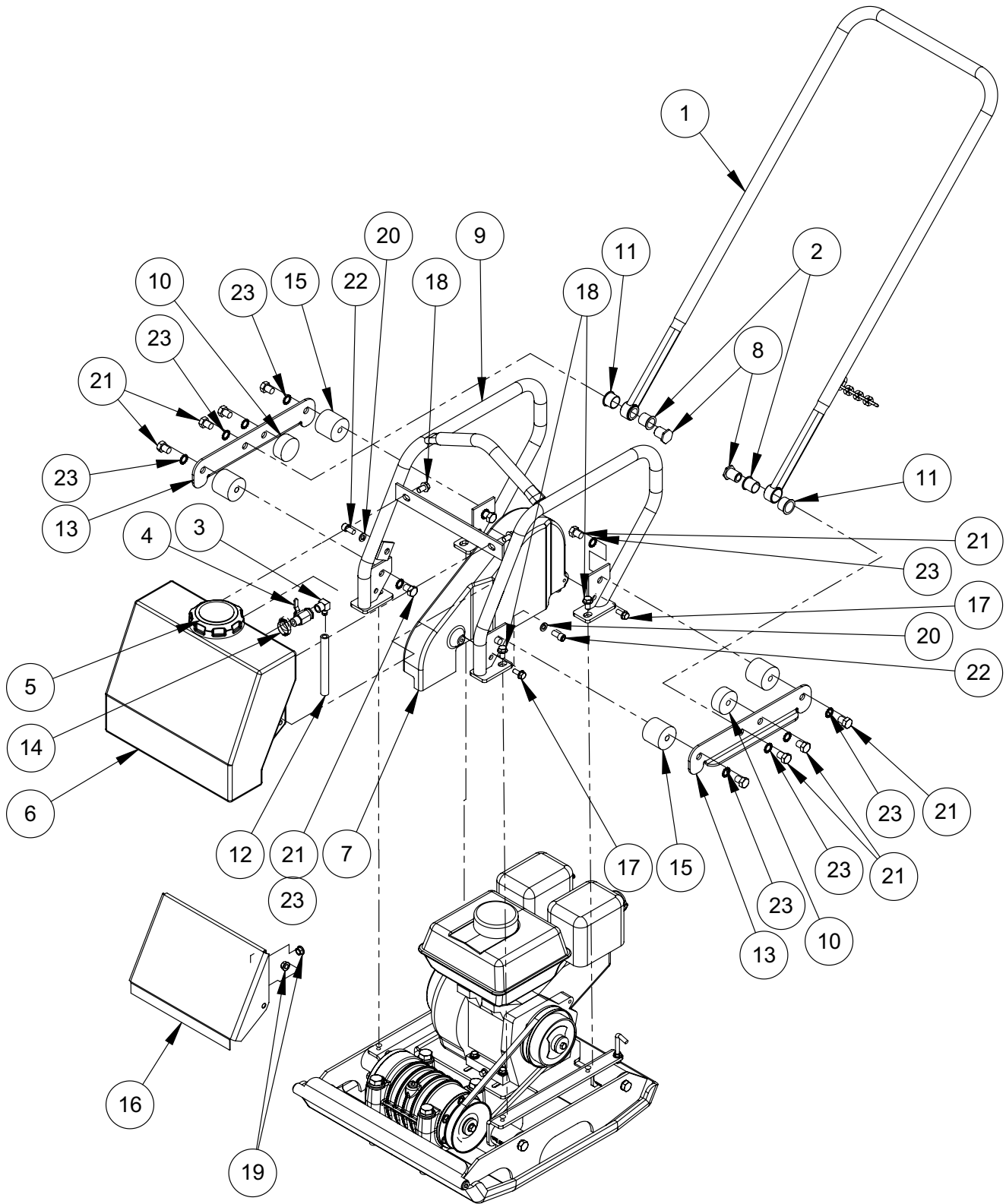

ROLLCAGE ASSEMBLY

ITEM	PART NO.	DESCRIPTION	2000	3550
1.	00226	HANDLE, COATED (INCLUDES ITEMS 2 & 11)	1	1
2.	01019	HANDLE BUSHING, INNER	2	2
3.	12891	FITTING, 90 DEG. MALE, 3/8 NPT, BRASS	1	1
4.	13947	BALL VALVE, 3/8 NPT, BRASS	1	1
5.	14202	CAP, WATER TANK	1	1
6.	16706	KIT, WATER TANK, AP2000 (Includes Items: 3, 4, 5, 12 & 14)	1	
7.	18754	KIT, WATER TANK, AP3550 (Includes items: 3, 4, 5, 12 & 14)		1
	15765	BELT GUARD	1	
	18690	BELT GUARD		1
8.	15830	HANDLE ATTACHMENT NUT	2	2
9.	15941	ROLL CAGE, COATED	1	1
10.	16189	SHOCK MOUNT	2	2
11.	16191	HANDLE BUSHING, OUTER	2	2
12.	16201	HOSE, WATER TANK, 3/8 X 5.25 LG.	1	
	18583	HOSE, WATER TANK, 3/8 X 7.250 LG.		1
13.	21665	KIT, (2) LIFT HANDLE, COATED	1	1
14.	16365	CLAMP, WATER TANK	1	1
15.	17170	SHOCK MOUNT	4	4
16.	17722	COVER PLATE, GP2000	1	
	18722	COVER PLATE, GP3550		1
17.	F051806FWS	FWLS, 5/16-18 x 3/4 LG., ZP	2	2
18.	F061605FWS	FWLS, 3/8-16 x 5/8 LG., ZP	6	6
19.	F0616FN	FLANGE WHIZ-LOCK NUT, 3/8-16, ZP	4	4
20.	F06LW	LOCKWASHER, 3/8, ZP	2	2
21.	F081305HCS	HHCS, 1/2-13 x 5/8 LG., GRADE 5, ZP	16	16
22.	F061606SCSSS	SOCKET HEAD CAP SCREW, 3/8-16 x 3/4 LG., STAINLESS STEEL	2	2
23.	M12ETLW	LOCKWASHER, M12, EXTERNAL TOOTH	4	4
		<u>KITS:</u>		
	18714	KIT CONVERSION FROM SOIL TO ASPHALT (AP2000)	1	
	19254	KIT CONVERSION FROM SOIL TO ASPHALT (AP3550)		1
	21103	KIT, PAVER PAD, 2000	1	
	21104	KIT, PAVER PAD, 3550		1
	20856	2000 PLATE WHEEL KIT	1	

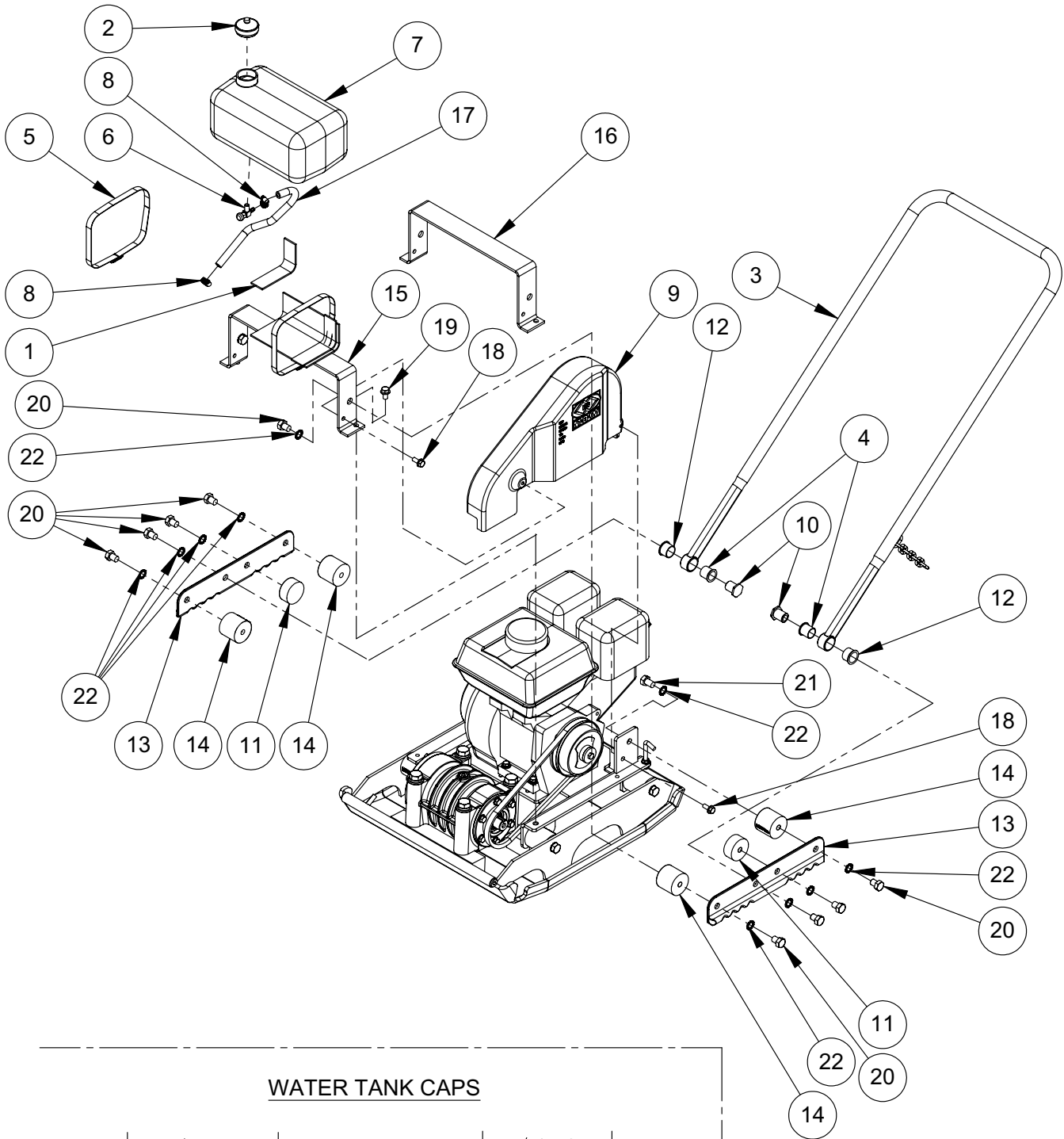

WATER TANK CAPS

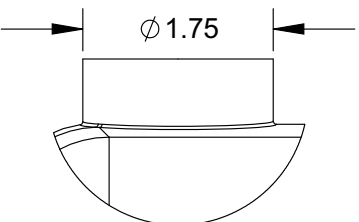

USE TANK CAP #19495

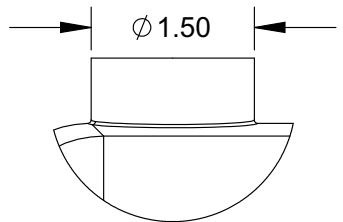

USE TANK CAP #00196

2018 ASSEMBLY

ITEM	PART NO.	DESCRIPTION	AP2018	GP2018
1.	00044	PAD, RUBBER	2	
2.	19495	CAP, WATER TANK - FOR USE WITH 1.75" OD TANK	1	
3.	00196 00226	CAP, WATER TANK - FOR USE WITH 1.50" OD TANK HANDLE, COATED	1	1
4.	01019	BUSHING, INNER, HANDLE	2	2
5.	01026	WORM DRIVE CLAMP	2	
6.	05578	VALVE FITTING, DAPCO	1	
7.	06326	WATER TANK, PLASTIC	1	
8.	08442	WORM DRIVE CLAMP	2	
9.	15765	BELT GUARD	1	1
10.	15830	HANDLE ATTACHMENT NUT	2	2
11.	16189	SHOCKMOUNT, HANDLE	2	2
12.	16191	BUSHING, OUTER, HANDLE	2	2
13.	21665	KIT, (2) LIFT HANDLES, COATED	1	1
14.	17170	SHOCKMOUNT, 2" O.D. x 1-3/4" LG.	4	4
15.	19449	BRACKET, WATER TANK	1	
16.	19460	BRACKET, HANDLE MOUNT		1
17.	19454	WATER HOSE, 5/16 x 9.5	1	
18.	F051806FWS	FLANGE WHIZ-LOCK SCREW, 5/16-18 x 3/4" LG, ZP	2	2
19.	F061605FWS	FLANGE WHIZ-LOCK SCREW, 3/8-16 x 5/8" LG, ZP	2	2
20.	F081305HCS	HEX HEAD CAP SCREW, 1/2-13 x 5/8" LG. ZP.	10	10
21.	F081306HCS	HEX HEAD CAP SCREW, 1/2-13 x 3/4" LG. ZP.	2	2
22.	M12ETLW	LOCKWASHER, M12, EXTERNAL TOOTH	12	12
		KITS:		
	00330	WATER TANK ASM. (INCLUDES TANK, CAP & VALVE)		
	21103	KIT, PAVER PAD		
	20856	2000 PLATE WHEEL KIT		

WARRANTY

1. IN GENERAL - The warranties described in this document are provided by M-B-W, INC. and MBW EUROPE, LTD. ("MBW") to define what is, what is not, and for how long machines and parts are covered against material defects and/or defective workmanship. To obtain warranty service, the purchaser must, within the Warranty Period (defined in Paragraph 3): (i) report the product defect to an authorized repair center, (ii) make a written request for repair, (iii) provide proof of purchase to the authorized repair center, and (iv) deliver the equipment to the authorized repair center. A list of authorized repair centers is available on the MBW website (mbw.com) or by contacting MBW at 800-678-5237.

2. COVERED - MBW's obligation under this limited warranty is limited to the cost of the parts and the labor to repair any defect in material and/or workmanship at an authorized MBW repair center. Transportation charges are not covered by this limited warranty.

3. WARRANTY PERIODS - The Warranty Period begins on, as applicable: (i) the product purchase date by an end user or (ii) the first day the product is put into rental or two years after invoice date from MBW to Dealer, whichever starts the warranty period first. To insure that your warranty is in place, fill out the warranty card and mail it in or register your product online at www.mbw.com/service-support/warranty-registration. The warranty is nontransferable.

The Warranty Period ends after:

- A. New Ground compaction equipment - 2 years.
 - B. New Concrete finishing equipment - 1 year.
 - C. New Utility equipment - 1 year.
 - D. Demonstration equipment - 6 months.
 - E. Wear parts: lubricants, filters, belts and shock mounts - 30 days.
4. NOT COVERED- This warranty does not include, and MBW specifically excluded from any warranty:
- A. Used equipment - all used equipment is not warranted and is sold 'as is' 'where is' with all defects.
 - B. Replacement electrical parts, including but not limited to: electric motors, circuit boards, switches, are not warranted or returnable.
 - C. OEM: engines, batteries, and chargers. Those warranties are covered by the manufacturer.
 - D. Consumable parts: trowel and screed blades.
 - E. Equipment that has been: altered, abused, neglected, not maintained, or modified to run outside its specifications. Any modification to the machine or its parts makes this warranty null and void.
 - F. Other: damage to a product from normal wear, air freight, overtime, pickup and delivery, temporary replacement rentals, freight damage, or other similar incidents.
 - G. Product used in a fashion it was not designed for.
 - H. Parts and labor not performed by authorized dealers.

It is at MBW's discretion if warranty applies and has the right to adjust labor rates on a claim by claim basis.

5. OTHER - IT IS EXPRESSLY AGREED THAT THIS SHALL BE THE SOLE AND EXCLUSIVE REMEDY UNDER THIS WARRANTY. UNDER NO CIRCUMSTANCES SHALL MBW BE LIABLE FOR ANY COSTS, LOSS, EXPENSE, DAMAGE, SPECIAL DAMAGES, DIRECT DAMAGES, INCIDENTAL DAMAGES, EXEMPLARY, CONSEQUENTIAL, OR PUNITIVE DAMAGES ARISING DIRECTLY OR INDIRECTLY FROM THE USE OF MBW PRODUCT OR DAMAGES FOR LOSS OF USE, LOSS OF ANTICIPATED PROFITS, INCOME, OR ECONOMIC LOSSES OF ANY KIND. MBW'S LIABILITY TO BUYER UNDER THESE WARRANTIES FOR THE PRODUCT IS LIMITED AS SET FORTH HEREIN, WHETHER BASED UPON WARRANTY, CONTRACT, NEGLIGENCE, TORT, STRICT LIABILITY OR ANY OTHER THEORY OF LIABILITY, INCLUDING BUT NOT LIMITED TO FRAUD, MISREPRESENTATION, BREACH OF CONTRACT, PERSONAL INJURY, PRODUCTS LIABILITY OR ANY OTHER THEORY.

MBW'S LIABILITY UNDER ANY WARRANTY HEREUNDER, WHETHER EXPRESS OR IMPLIED, SHALL NOT EXCEED THE COST OF REPAIR OR REPLACEMENT OF DEFECTIVE PARTS OF THE PRODUCT OR THE PRODUCT. BUYER MAY NOT BRING ANY ACTION UNDER THESE WARRANTIES MORE THAN ONE YEAR AFTER THE CAUSE OF ACTION HAS ACCRUED.

THE FORGOING WARRANTY IS EXPRESSED IN LIEU OF ALL OTHER WARRANTIES, EXPRESSED OR IMPLIED, INCLUDING THE WARRANTIES OF MERCHANTABILITY, FITNESS FOR USE, AND FITNESS FOR A PARTICULAR PURPOSE, AND ALL OTHER OBLIGATIONS OR LIABILITY ON MBW'S PART. MBW SPECIFICALLY DISCLAIMS AND EXCLUDES ANY AND ALL WARRANTIES OF MERCHANTABILITY AND FITNESS FOR A PARTICULAR PURPOSE.

MBW NEITHER ASSUMES NOR AUTHORIZES ANY OTHER PERSON TO ASSUME ON BEHALF OF MBW ANY OTHER LIABILITY OR WARRANTY IN CONNECTION WITH THE SALE OR SERVICE OF ANY MBW PRODUCT.

Some states do not allow limitations on how long an implied warranty lasts, so the above limitation may not apply to you. This warranty gives you specific legal rights, and you may also have other rights which vary from state to state.