

OPERATOR'S SAFETY AND SERVICE MANUAL

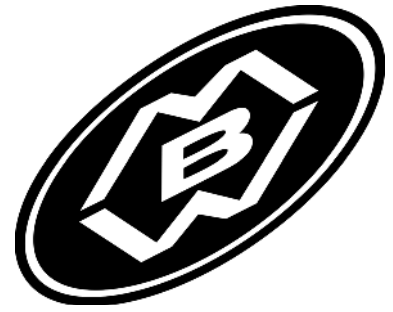

GP5800

This manual covers the following serial numbers
and higher for each model listed:

GP5800.....5800001



VIBRATORY PLATE

MBW, Inc.
250 Hartford Rd • PO Box 440
Slinger, WI 53086-0440
Phone: (262) 644-5234
Fax: (262) 644-5169
Email: mbw@mbw.com
Website: www.mbw.com

MBW (UK) Ltd.
Units 2&3 CochraneStreet
Bolton BL3 6BN
England, UK
Phone: 44 (0) 01204 387784
Fax: 44 (0) 01204 387797
E-mail: mbwuk@btinternet.com

MBW FRANCE S.A.R.L.
Phone: +33 (0) 3 44 07 15 96

L20016 / 05.19.G
©MBW, Inc. 2015
Printed in the USA

TABLE OF CONTENTS

SAFETY INFORMATION	1	Cleaning Plate	5
Introduction	1	Belt Adjustment	5
Safety Precautions	1	Checking Exciter Oil	6
Safety Decals	1	Changing Exciter Oil	7
SPECIFICATIONS	3	SERVICE	8
OPERATION	4	Torque Chart	8
Introduction	4	Service Tools	8
Before Starting & Operating	4	Engine Removal	8
Starting Engine	4	Exciter Removal	8
Operating	4	Exciter Disassembly	9
Stopping Engine	4	Exciter Assembly	9
Lifting/Transporting	4	Exciter installation	10
MAINTENANCE	5	Parts Replacement Cycles and Tolerances	10
Maintenance Schedule	5	REPLACEMENT PARTS	11
Fluid Levels	5	Exciter Assembly	12
Engine Maintenance	5	Engine Assembly	14
Engine Speed	5	Roll Cage Assembly	16
		WARRANTY	18



WARNING



CALIFORNIA PROPOSITION 65 WARNING

Engine exhaust and some of its constituents and dust produced during the use of this product contain chemicals known in the state of California to cause cancer, birth defects, and other reproductive harm.

SAFETY INFORMATION

Introduction



This Safety Alert Symbol is used to call attention to items or operations which may be dangerous to those operating or working with this equipment.

The symbol can be found throughout this manual and on the unit. Please read these warnings and cautions, along with all decals, carefully before attempting to operate the unit. Make sure every individual who operates or works with this equipment is familiar with all safety precautions.

WARNING

GENERAL WARNING. Indicates information important to the proper operation of the equipment. Failure to observe may result in damage to the equipment and/or severe bodily injury or death.

CAUTION

GENERAL CAUTION. Indicates information important to the proper operation of the equipment. Failure to observe may result in damage to the equipment.

Safety Precautions



LETHAL EXHAUST GAS: An internal combustion engine discharges carbon monoxide, a poisonous, odorless, invisible gas. Death or serious illness may result if inhaled. Operate only in a properly ventilated area. **NEVER OPERATE IN A CONFINED AREA!**



DANGEROUS FUELS: Use extreme caution when storing, handling and using fuels, as they are highly volatile and explosive in vapor state. Do not add fuel while engine is running. Stop and cool the engine before adding fuel. **DO NOT SMOKE!**



SAFETY GUARDS: It is the owner's responsibility to ensure that all guards and shields are in place and in working order.



IGNITION SYSTEMS: Breakerless, magneto, and battery ignition systems can cause severe electrical shocks. Avoid contacting these units or their wiring.



SAFE DRESS: Do not wear loose clothing, rings, wristwatches, etc. near machinery.



NOISE PROTECTION: Wear OSHA specified hearing protection devices.

EYE PROTECTION: Wear OSHA specified eye shields, safety glasses, and sweat bands.



FOOT PROTECTION: Wear OSHA specified steel-tipped safety shoes.

HEAD PROTECTION: Wear OSHA specified safety helmets.



OPERATOR: Keep children and bystanders off and away from the equipment.



DUST PROTECTION: Machining, crushing or handling of stone, concrete, masonry, metal and other materials may generate dust, mist and fumes containing chemicals such as silica, known to cause serious or fatal injury or illness, such as respiratory disease, silicosis, cancer, birth defects, or other reproductive harm.

silica, known to cause serious or fatal injury or illness, such as respiratory disease, silicosis, cancer, birth defects, or other reproductive harm.

- Control dust, mist and fumes at the source where possible. Water should be used to control dust whenever feasible.

- Use good work practices and follow the recommendations of the manufacture, OSHA/NIOSH and other occupational trade associations.

- When hazards cannot be eliminated the operator and any bystanders should always wear a OSHA specified respirator for materials being handled.

REFERENCES: For details on safety rules and regulations in the United States, contact your local Occupational Safety and Health Administration (OSHA) office. Equipment operated in other countries must be operated and serviced in accordance and compliance with any and all safety requirements of that country. The publication of these safety precautions is done for your information. MBW does not by the publication of these precautions, imply or in any way represent that these are the sum of all dangers present near MBW equipment. If you are operating MBW equipment, it is your responsibility to insure that such operation is in full accordance with all applicable safety requirements and codes. All requirements of the United States Federal Occupational Safety and Health Administration Act must be met when operated in areas that are under the jurisdiction of that United States Department.

Safety Decals

Carefully read and follow all safety decals. Keep them in good condition. If decals become damaged, replace as required. If repainting the unit, replace all decals. Decals are available from authorized MBW distributors. Order the decal set listed on the following page(s).

WARNING
 Operating, servicing and maintaining this equipment can expose you to chemicals, including engine exhaust, phthalates and lead, which are known to the state of California to cause cancer and birth defects or other reproductive harm. Avoid breathing engine exhaust. Do not operate equipment in confined areas. For more information go to www.P65Warnings.ca.gov



21820

12500



21139

GP5800

21140

CAUTION
 Read the Operating Instructions before operating this piece of equipment.
 Keep unauthorized and untrained people away from this equipment.
ROTATING & MOVING PARTS! Make sure all guards and safety devices are in place.
 Avoid breathing dust from operating machine, wear OSHA specified dust mask/respirator.
 Failure to comply could result in serious bodily injury.

20019

CAUTION
 HOT SURFACE
 DO NOT TOUCH
 SURFACE CHAUDE
 NE PAS TOUCHER

09311



21742

CAUTION
 Machine may fall and cause injury or damage if lifted improperly. Lift by handles or rollcage only.

GP2000=165 lbs (75 kg)	AP3550=254 lbs (115 kg)
AP2000=193 lbs (88 kg)	GP5800=300 lbs (136 kg)
GP3550=226 lbs (103kg)	

16402

WARNING
 OPERATION OF THIS EQUIPMENT MAY CREATE SPARKS THAT CAN START FIRES AROUND DRY VEGETATION. A SPARK ARRESTER MAY BE REQUIRED. THE OPERATOR SHOULD CONTACT LOCAL FIRE AGENCIES FOR LAWS OR REGULATIONS RELATING TO FIRE PREVENTION

19791

WARNING
 ROTATING PARTS can crush and cut. Keep hands away!

12573

PLATES OPERATING INSTRUCTIONS

1. Check engine oil.
2. Open fuel valve.
3. Choke engine. A warm engine may not need to be choked.
4. Open throttle part way.
5. Pull starter rope.
6. After starting: open choke, return throttle to idle position.
7. During operation, when excessive kickback is noticed, maximum compaction has been reached.
8. To stop: Return throttle to idle position, use engine stop switch, close fuel valve.

13482

Safety Decals (Decal Set #12100)

SPECIFICATIONS

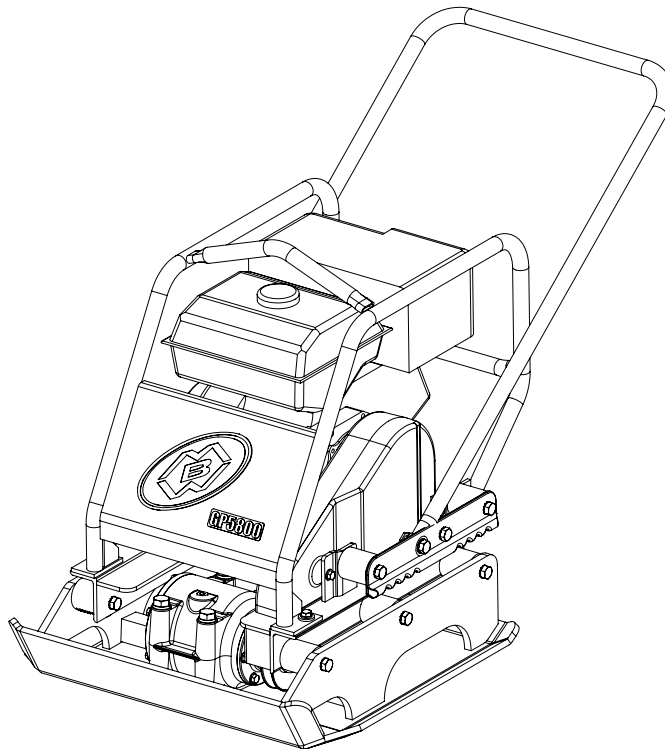

	GP5800H
Centrifugal Force	5800 lbf (25.8 kN)
Exciter Speed	4800 vpm
Travel Speed	130 ft./min. (39.6 m/min.)
Compaction Depth	20 in (51 cm)
Plate Size (W x L)	23 x 24 in (58 x 61 cm)
Operating Weight	289 lb. (131 kg)
Engine Speed	3400 rpm
Operating Noise Level¹	96 dBA
Compaction Area	14950 sqft/h (1389 sqm/h)
Engine Model	Honda GX270

Specifications subject to change without notice.

- No universal method or formula has been accepted for determining “Compaction Force”. All manufactures employ their own method or formula.

OPERATION

Introduction

MBW equipment is intended for use in very severe applications. They are powered by four cycle engines and are available in different sizes and a selection of engines.

This parts manual contains only standard parts. Variations of these parts as well as other special parts are not included. Contact your local MBW distributor for assistance in identifying parts not included in this manual.

Before Starting & Operating

- **HANDLE INSTALLATION** - Refer to Roll Cage Assembly, page 16. Install handle by removing handle attachment nuts. Reinstall handle attachment nut through the handle bushings from the inside in. Make sure nylon bushings inside the handle stay in place.
- **REMEMBER!** It is the owner's responsibility to communicate information on the safe use and proper operation of this unit to the operators.
- Review ALL of the Safety Precautions listed on page 1 of this manual.
- Familiarize yourself with the operation of the machine and confirm that all controls function properly.
- Know how to STOP the machine in case of an emergency.
- Make sure hands, feet, and clothing are at a safe distance from any moving parts.
- **OIL LEVEL** - Check the oil level in the engine. For more information see "Lubrication" under the respective engine's "Owners Manual" or the Maintenance section of this manual.
- **AIR CLEANER** - Check to ensure element is in good condition and properly installed.
- **FUEL SUPPLY** - The engines on MBW equipment require an automotive grade of clean, fresh, unleaded gasoline.
- **FUEL FILTER** - If clogged or damaged, replace.

Starting Engine

1. Open fuel valve.
2. Turn engine switch to "ON".
3. Set throttle to idle.
4. Choke engine if necessary (you may not need to choke a warm engine).

5. Pull starter rope repeatedly until engine starts.
6. Move choke lever to open position.
7. Allow engine to warm up for one or two minutes.

Operating

1. Open throttle fully.
2. Compactor will begin vibrating and moving in a forward direction.
3. Maximum compaction of soil has been reached when excessive kickback is noticed in the compactor. The number of passes needed to reach compaction level desired will depend on soil type and moisture.

Stopping Engine

1. Move throttle to idle position.
2. Let engine idle for one or two minutes.
3. Turn switch on engine to "STOP" position.
4. Turn off fuel valve.

Lifting/Transporting

1. The unit can be lifted by the handles on the sides of the unit or by the roll cage.
2. The unit must be transported in the upright position. DO NOT lay machine on its side or top.
3. Secure or tie down unit using the lift handles or roll cage.

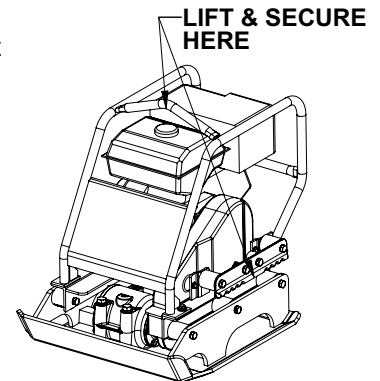

WARNING



Always stop the engine before:

Adding fuel.

Leaving the equipment unattended for any amount of time.

Before making any repairs or adjustments to the machine.

MAINTENANCE



WARNING



Always exercise the stopping procedure before servicing or lubricating the unit.

After servicing the unit, replace and fasten all guards, shields, and covers to their original positions before resuming operation.



CAUTION



Always verify fluid levels and check for leaks after changing fluids.

Do not drain oil onto ground, into open streams, or down sewage drains.

Maintenance Schedule

SYSTEM	MAINTENANCE	EACH USE	EVERY 50 HOURS	EVERY 250 HOURS	YEARLY
Engine	Refer to engine operator/owner manual	X			
Exciter	Check oil level		X		
	Check for oil leaks	X			
	Change oil			X	X
	Tighten Bolts ¹		X		X
Hardware	Check and tighten as needed ¹		X		X
Shockmounts	Check for cracks or tears		X		X

1. Check all hardware after the first 5 hours of use, then follow the maintenance schedule.

Fluid Levels

SYSTEM	FLUID VOLUME	RECOMMENDED OIL
Exciter	6 oz.	MBW Ground Pounder [®] Exciter Oil ¹
Engine	Refer to engine operator/owner manual	

1. MBW #01058---- 6-Pack (8 oz. bottles)
MBW #17320---- 1 quart (32 oz.)

Engine Maintenance

Refer to the engine Owner's Manual for maintenance intervals and procedures.

Engine Speed

1. Engine speed is factory set according to the speeds listed in the Specifications section of this manual. Do not tamper with the governor setting, the governor establishes safe operating limits which must not be exceeded.
2. Refer to the engine Owner's Manual for procedure on setting operating and idle speed.
3. The engine operating speed should be set to 3400 RPM.

4. The engine idle speed must not exceed 1800 rpm. If the idle speed is greater than 1800 RPM the clutch may not disengage.

Cleaning Plate

Remove any excess debris which may get into the housing of the unit.

Belt Adjustment

If any belt stretch develops follow these steps:
Refer to Roll Cage Assembly, page 16.

1. Remove two hex head flange bolts (#10) securing belt guard to roll cage & engine deck and remove belt guard. (See Figure 1)

2. Apply moderate thumb pressure to belt about half way between pulleys. When properly adjusted the belt should deflect approximately 3/8" (9mm). If the belt is adjusted correctly reinstall belt guard and hardware.
3. To adjust belt tension loosen (do not remove) the four engine bolts.
4. Push engine towards the back of the plate. While holding pressure on the engine retighten the four engine bolts.
5. Recheck belt tension as described in Step 2 and readjust if necessary until the proper tension is reached.
6. Reinstall belt guard and hardware.

5. Remove four hex head screws (#11), lock washers (#12) and flat washers (#13). (See Figure 2)
6. Lift roll cage and handle assembly off of engine deck.
7. Clean all dirt and debris from exciter to prevent contamination of exciter oil.
8. Remove pipe plug from top of exciter housing.
9. Rotate exciter shaft so a metal dip stick can be inserted into exciter (see Figure 3).
10. Place a clean metal rod through the oil fill hole as shown in Figure 3.
11. Exciter should have approximately 7/8 to 1" oil.
12. If oil needs to be added, refer to Fluid Levels page of this section for type of oil to be used. DO NOT OVERFILL, over filling can cause excessive heat in exciter.

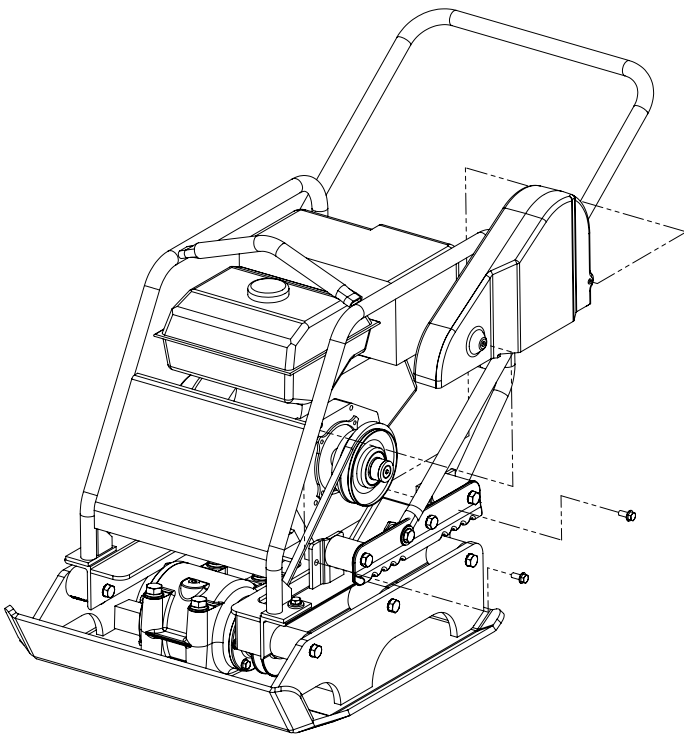

FIGURE 1

Checking Exciter Oil

Refer to Roll Cage Assembly, page 16.

WARNING
<p>Exciter and oil are hot after machine has been running. Allow machine to cool before servicing unit.</p>

1. Let exciter cool before checking oil.
2. Place plate on a level surface.
3. Remove belt guard as described in Belt Adjustment section of this manual. (See Figure 1)
4. Remove two hex head screws (#15) and lock washers (#16) securing front handle shock mounts to engine deck. (See Figure 2)

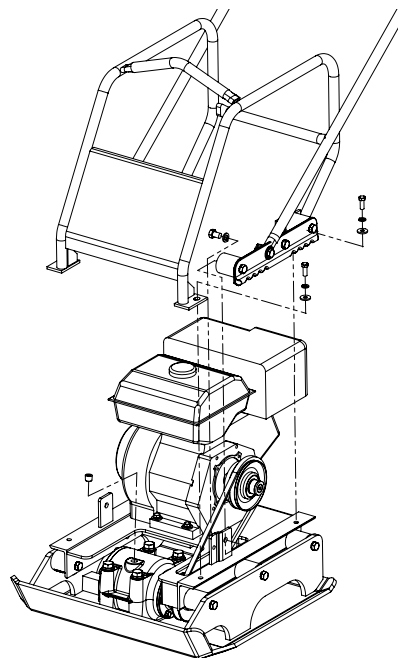

FIGURE 2

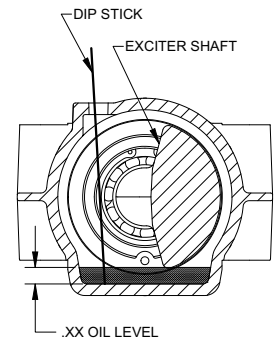

FIGURE 3

13. Apply pipe sealant to pipe plug and reinstall into top of exciter housing.
14. Place roll cage assembly on engine deck.
15. Reinstall four hex head screws (#11), lock washers (#12) and flat washers (#13), hand tight only. (See figure 2)
16. Reinstall two hex head screws (#15) and lock washers (#16) securing front handle shock mounts to engine deck. Slide roll cage forward or backward to line-up mounting holes with front handle shock mounts. (See Figure 2)
17. Assemble belt guard to roll cage and tighten all roll cage hardware.

Changing Exciter Oil



WARNING



Exciter and oil are hot after machine has been running. Allow machine to cool before servicing unit.

1. Let exciter cool before changing oil.
2. Remove belt guard as described in Belt Adjustment section of this manual. (See Figure 1)
3. Loosen, do not remove, four engine mounting screws and slide engine towards front of machine and remove belt.

Refer to Engine Assembly, page 14.

4. Remove five hex head screws (#15) and lock washer (#16) from base plate and remove engine deck & roll cage assembly. (See Figure 4)

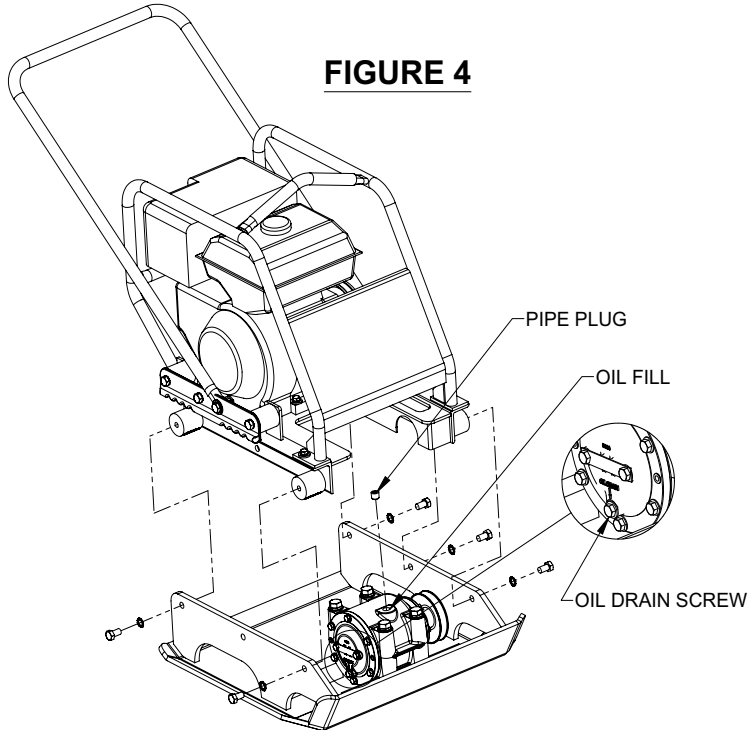

5. Clean all dirt and debris from exciter to prevent contamination of exciter oil.

Refer to Exciter Assembly, page 12.

6. Remove pipe plug (#26) from top of exciter housing.
7. Remove oil drain screw (#21) and brass washer (#25) from exciter rear cover. Tilt bottom plate housing on it's side to drain oil from housing. After draining oil, return bottom plate housing to the upright position and replace oil drain screw (#21) and brass washer (#25).
8. Fill exciter with MBW Ground Pounder® exciter oil to level specified in the Fluid Levels section of this manual.
9. Apply pipe sealant to pipe plug and reinstall into top of exciter housing.
10. Reinstall engine deck & roll cage assembly, belt and belt guard.
11. Adjust belt tension as specified in Belt Adjustment section of this manual.

SERVICE

Assembly and disassembly should be performed by a service technician who has been factory trained on MBW equipment. The unit should be clean and free of debris. Pressure washing before disassembly is recommended.

- Prior to assembly, wash all parts in a suitable cleaner or solvent.
- Check moving parts for wear and failure. Refer to the Replacement section in this manual for tolerance and replacement cycles.
- All shafts and housings should be oiled prior to pressing bearings. Also, ensure that the bearings are pressed square and are seated properly.
- All bearings should be replaced when rebuilding any exciter or gearbox.
- All gaskets and seals should be replaced after any disassembly.

Torque Chart

SIZE	GRADE 2	GRADE 5	GRADE 8
1/4-20	49 in•lbs	76 in•lbs	9 ft•lbs
1/4-28	56 in•lbs	87 in•lbs	10 ft•lbs
5/16-18	8 ft•lbs	13 ft•lbs	18 ft•lbs
5/16-24	9 ft•lbs	14 ft•lbs	20 ft•lbs
3/8-16	15 ft•lbs	23 ft•lbs	33 ft•lbs
3/8-24	17 ft•lbs	26 ft•lbs	37 ft•lbs
7/16-14	24 ft•lbs	37 ft•lbs	52 ft•lbs
7/16-20	27 ft•lbs	41 ft•lbs	58 ft•lbs
1/2-13	37 ft•lbs	57 ft•lbs	80 ft•lbs
1/2-20	41 ft•lbs	64 ft•lbs	90 ft•lbs
9/16-12	53 ft•lbs	82 ft•lbs	115 ft•lbs
5/8-11	73 ft•lbs	112 ft•lbs	159 ft•lbs
5/8-18	83 ft•lbs	112 ft•lbs	180 ft•lbs
3/4-16	144 ft•lbs	200 ft•lbs	315 ft•lbs
1-8	188 ft•lbs	483 ft•lbs	682 ft•lbs
1-14	210 ft•lbs	541 ft•lbs	764 ft•lbs
1-1/2-6	652 ft•lbs	1462 ft•lbs	2371 ft•lbs
M 6	3 ft•lbs	4 ft•lbs	7 ft•lbs
M 8	6 ft•lbs	10 ft•lbs	18 ft•lbs
M 10	10 ft•lbs	20 ft•lbs	30 ft•lbs

CONVERSIONS

in•lbs x 0.083 = ft•lbs

ft•lbs x 12 = in•lbs

ft•lbs x 0.1383 = kg•m

ft•lbs x 1.3558 = N•m

Service Tools

Part No.	Description
17320	Ground Pounder® Exciter Oil
016129	Rubber Test Mat
12100	Decal Set
20190	Service Kit

Engine Removal

Refer to Roll Cage Assembly, page 16.

1. Remove two hex head flange bolts (#10) securing belt guard to roll cage & engine deck and remove belt guard.
2. Remove four hex head screws (#11), lock washers (#12) and flat washers (#13). Lift roll cage & handle assembly off engine deck.

Refer to Engine Assembly, page 14.

3. Remove four engine mounting hex head screws (#10), lock washers (#11), washers (#12) and engine mounting bars (#4).
4. Remove belt (#3), and lift engine off of engine deck (#9).

Exciter Removal

1. Remove belt guard as described above.
2. Loosen, do not remove, four engine mounting screws (#10) and slide engine towards front of machine and remove belt.

Refer to Engine Assembly, page 14.

3. Remove five hex head screws (#15) and lock washer (#16) from base plate and remove engine deck & roll cage assembly. (See figure 4)

Refer to Exciter Assembly, page 12.

4. Remove four exciter bolts (#12), lock washers (#27), washers (#28) and nuts (#13). If unit has exciter shims (#3) make note of location to assure proper placement during reassembling.
5. Clean exciter and drain oil as described in Changing Exciter Oil section of this manual before proceeding with disassembly.

Exciter Disassembly

Refer to Exciter Assembly, page 12.

1. Remove flat head screw (#23) and countersunk washer (#11) securing the pulley (#15) to the exciter shaft (#17).
2. Slide pulley off of exciter shaft. be sure not to lose shaft key (#14).

Note: To aid in removal of rear cover you will need two 5/16-18 bolts, minimum grade 5.

3. Remove six flange screws (#24) from rear cover (#18). To press rear cover (#18) off of housing, thread two 5/16-18 grade 5 bolts into thread holes on cover. Turn bolts in with wrench or ratchet to press cover out. When pressing cover off try to keep even pressure on both side to ensure cover comes out straight.
4. Remove six flange screws (#22) from front cover (#16) and remove front cover.
5. Remove snap ring (#10) from exciter shaft (#17).
6. Support exciter assembly on outside diameter of exciter housing (#1) and press exciter shaft out of housing.

Note: If bearings have failed and need to be replace then proceed with bearing removal step 6. If bearings do not need replacing skip to step #11.

7. Support exciter housing (#1) and press out front bearing (#9) from inside out.
8. Remove snap ring (#4).
9. Remove bearing (#8) from rear cover (#18) with 1/4" punch. Tap the bearing out thru the holes for caps screws (#21). Be sure to alternate between holes to avoid cocking the bearing.
10. Remove bearing (#8) inner race from exciter shaft by supporting O.D. of race and pressing exciter shaft thru.
11. Remove filter retainer plate (#2) and filter (#5) by removing two cap screws (#21).
12. Remove pipe plug (#26).

Exciter Assembly

Refer to Exciter Assembly, page 12.

1. Prior to assembly, clean all parts in a suitable solvent or cleaning solution. When a complete disassembly is done it is recommended that all seals, gaskets and bearings are replaced.

Note: If replacing bearings proceed to step #2, if not replacing bearings skip to step #6.

2. Press front bearing (#9) into exciter housing (#1).

3. Press bearing (#8) inner race onto exciter shaft (#17).
4. Install snap ring (#10) onto exciter shaft, opposite end as pulley.
5. Support I.D. and O.D. of bearing (#9) and press exciter shaft into bearing.
6. Install snap ring (#10) onto exciter shaft on pulley end.
7. Check felt filter (#5) to be sure it is not blocked or deteriorating, Replace if damaged.
8. Check and set end of spirol pin (#20) to be 3/16" from inside of rear cover (#18). See Figure 5.
9. Press bearing (#8) into rear cover (#18) and install snap ring (#4).

Note: To aid in assembly of rear cover you will need three, 5/16-18 x 2-1/2 minimum length bolts, to aid in alignment of rear cover.

10. Apply a light coating oil to I.D. of exciter housing.
11. Apply gasket maker around holes and to flange face of rear cover. (See Figure 5)
12. Set rear cover (#18) on exciter housing and install three alignment bolts into exciter housing.



Be sure that the inner bearing race is properly aligned to slide into the bearing. If proper alignment is not maintained the shaft may push the front bearing out of the housing.

13. Carefully press or tap the rear cover (#18) down to seat on the exciter housing. Use care to keep cover straight when installing to prevent damaging housing or cover.
14. Remove the three alignment bolts and install six flange screws (#24) securing the rear cover. Torque flange screws to 13 ft.-lbs.
15. Use medium strength thread lock when installing retainer plate (#2) with 2twocap screws (#21).
16. Install oil drain cap screw (#21) and brass washer (#25).

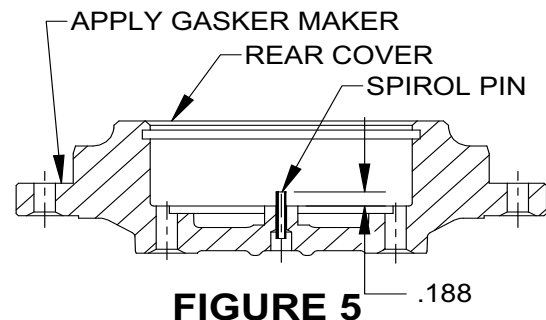

FIGURE 5 .188

Refer to Exciter Assembly, page 12.

17. Press oil seal (#6) into front cover (#16), Seal to be press in until flush with front cover.
18. Apply gasket maker around holes and to mounting flange face of front cover.
19. Install front cover (#16) and six flange screws (#22). Torque flange screws to 13 ft.-lbs.
20. Install key (#14) on exciter shaft and slide pulley (#15) onto shaft.
21. Install washer (#11) and flat head screw (#23), torque flange screw to 13 ft.-lbs.
22. Fill exciter with MBW Ground Pounder® exciter oil to level specified in the Fluid Levels section of this manual.
23. Apply pipe sealant to pipe plug (#26) and reinstall into top of exciter housing.

Exciter installation

Refer to Exciter Assembly, page 12.

1. Clean exciter mounting bars on bottom plate. If unit was equipped with exciter shims (#3) replace to original position and set exciter assembly in place on mounting bars.
2. Check to make sure exciter sits flat on mounting bars, if not shim (#3) as needed.
3. Install four exciter bolts (#12), lock washers (#27), washers (#28), and nuts (#13). Torque exciter bolts to 150 ft.-lbs.
4. Reinstall engine deck, belt and roll cage assembly. Adjust belt as describer in Belt Adjustment section of this manual.

Parts Replacement Cycles and Tolerances

Bearings	Replace anytime a bearing is rough, binding, discolored or removed from housing or shaft.
Clutch	Replace clutch if it does not disengage below 1800 rpm.
Engine Components	Refer to your engine manufacturer's Owner's Manual.
Hardware	Replace any worn or damaged hardware as needed. Replacement hardware should be grade 5 and zinc plated unless otherwise specified.
Safety Decals	Replace if they become damaged or illegible.
Seals & Gaskets	Replace if a leak is detected and at every overhaul or tear down.
V-Belts	Replace if cracked, torn, or stretched to the point the belt won't tension properly.
Exciter Oil	Replace once every season or every 250 hours. Use 6 oz. (5800 plate) Ground Pounder® exciter oil.

REPLACEMENT PARTS

The warranty is stated in this book on page 18. Failure to return the Warranty Registration Card renders the warranty null and void.

MBW has established a network of reputable distributors/dealers with trained mechanics and full facilities for maintenance and rebuilding, and to carry an adequate parts stock in all areas of the country. Their sales engineers are available for professional consultation. If you cannot locate an MBW distributor in your area, contact MBW or one of our Sales Branches listed below.

When ordering replacement parts, be sure to have the following information available:

- Model and Serial Number of machine when ordering MBW parts
- Model and Serial Number of engine when ordering engine parts
- Part Number, Description, and Quantity
- Company Name, Address, Zip Code, and Purchase Order Number
- Preferred method of shipping

REMEMBER - You own the best! If repairs are needed, use only MBW parts purchased from authorized MBW distributors.

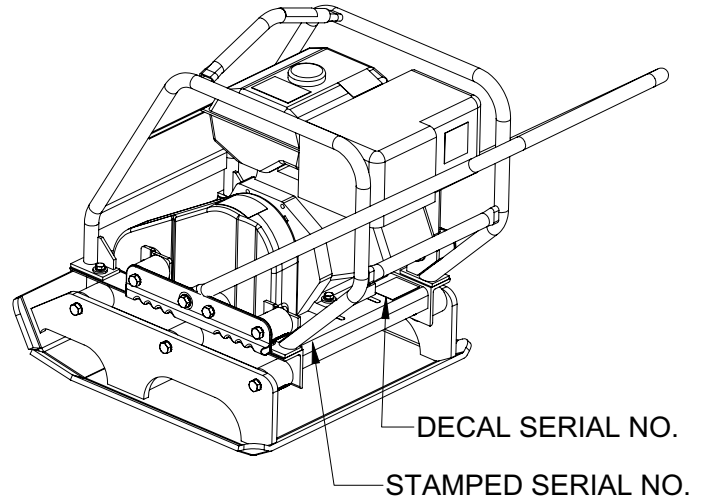

The unit's serial number can be found in the following locations:

- The model/serial number decal is located on the deck behind the engine.
- The serial number is stamped on the engine deck in the back left corner, top of exciter housing and on bottom plate exciter mounting bar.

Write Model Number here

Write Serial Number here

Contact Information

MBW, Inc.
250 Hartford Rd • PO Box 440
Slinger, WI 53086-0440
Phone: (262) 644-5234
Fax: (262) 644-5169
Email: mbw@mbw.com
Website: www.mbw.com

MBW (UK) Ltd.
Units 2 & 3 Cochrane Street
Bolton BL3 6BN, England
Phone: 01204 387784
Fax: 01204 387797

MBW FRANCE S.A.R.L.
Phone: +33 (0) 3 44 07 15 96

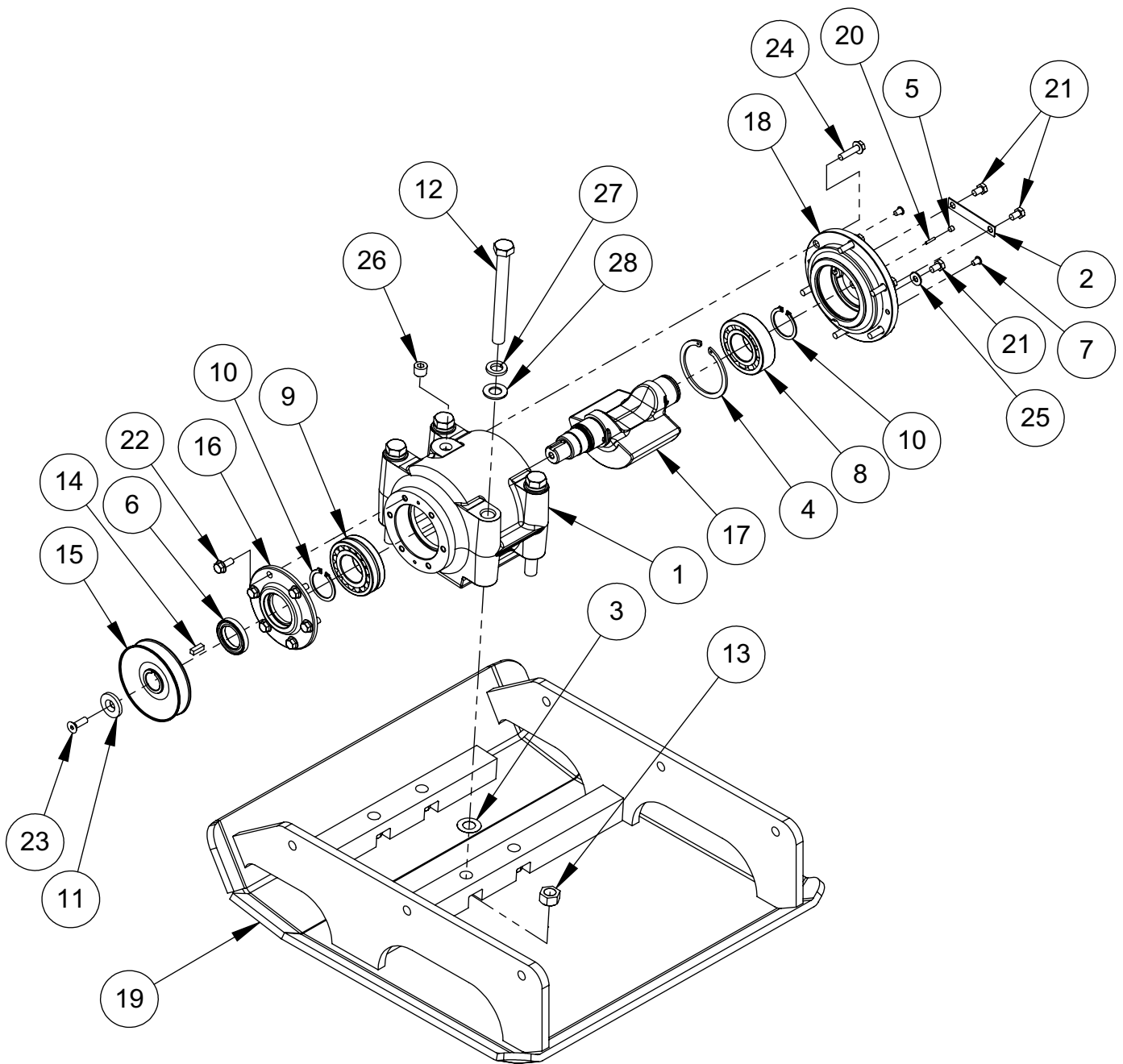

Exciter Assembly

ITEM	PART NO.	DESCRIPTION	QTY
1.	00001	EXCITER HOUSING	1
2.	00066	FILTER RETAINER	1
3.	00259	SHIM, EXCITER (AS REQUIRED)	
4.	01000	RETAINING RING, INTERNAL	1
5.	01072	FILTER, FELT	1
6.	01107	SHAFT SEAL	1
7.	05559	PLUG, PLASTIC	2
8.	07456	ROLLER BEARING	1
9.	07458	SPERICAL ROLLER BEARING	1
10.	07469	RETAINING RING, EXTERNAL	2
11.	14993	WASHER, COUNTERSUNK	1
12.	18700	HEX HEAD CAP SCREW, 5/8-11 x 6"LG. GRADE 8	4
13.	18701	HEX NUT, 5/8-11	4
14.	19135	SHAFT KEY, 1/4" SQUARE x 3/4" LONG	1
15.	19629	EXCITER PULLEY	1
16.	19991	COVER, FRONT	1
17.	19992	EXCITER SHAFT, 5800	1
18.	19993	COVER, BACK	1
19.	19986	BASE PLATE, GP5800	1
20.	F0205SP	SPIROL PIN, 1/8: DIA. x 5/8" LONG	1
21.	F051804HCS	HEX HEAD CAP SCREW, 5/16-18 x 1/2 LG.	3
22.	F051806FWS	FLANGE LOCK SCREW, 5/16-18 x3/4 LG.	6
23.	F051808FSS	FLAT HEAD SOCKET SCREW, 5/16-18 x 1" LG.	1
24.	F051808FWS	FLANGE LOCK SCREW, 5/16-18 x1 LG.	6
25.	F05BFW	BRASS FLAT WASHER	1
26.	F0618SPP	SOCKET PIPE PLUG, 3/8-18 NPT	1
27.	F10LW	LOCK WASHER, 5/8	4
28.	F10PW	PLAIN WASHER, 5/8	4
		REPLACEMENT KITS:	
	19990	EXCITER ASSEMBLY COMPLETE	
	18719	KIT, PAVER PAD	

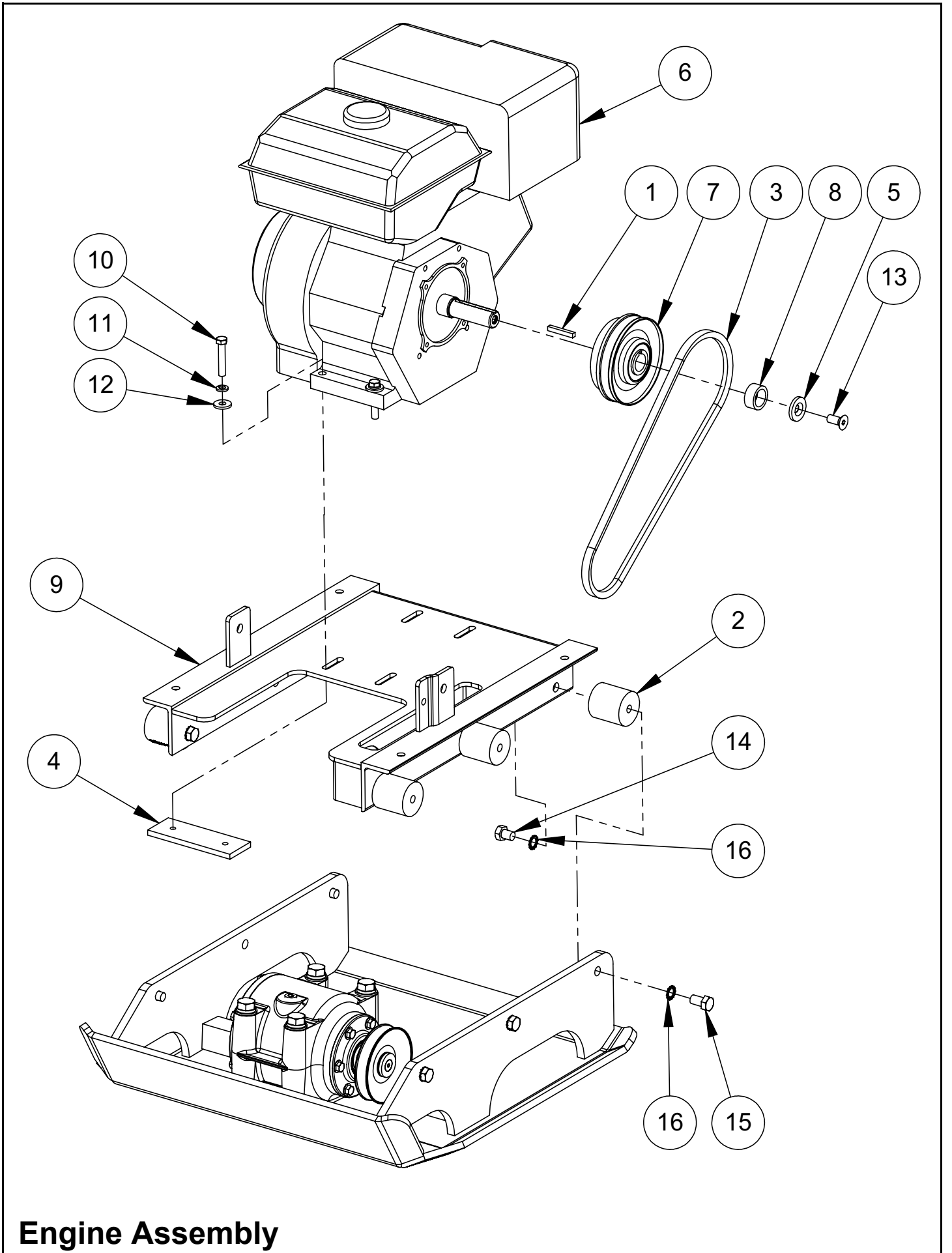

Engine Assembly

ITEM	PART NO.	DESCRIPTION	QTY
1.	00808	SHAFT KEY, 1/4" SQUARE X 1-3/4" lg.	1
2.	01011	SHOCK MOUNT	5
3.	05881	V-BELT, A37	1
4.	12968	ENGINE MOUNTING BAR	2
5.	14992	WASHER, COUNTERSUNK	1
6.	15674	HONDA ENGINE, GX270	1
7.	19127	CLUTCH, CENTRIFUGAL	1
8.	19136	SHAFT SPACER	1
9.	19994	ENGINE DECK ASSEMBLY	1
10.	F061616HCS	HEX HEAD CAP SCREW, 3/8-16 x 2" LG.	4
11.	F06LW	LOCKWASHER, 3/8"	4
12.	F06SW	STANDARD FLAT WASHER, 3/8"	4
13.	F072008FSS	FLAT HEAD SOCKET SCREW, 7/16-20 x 1" LG.	1
14.	F081305HCS	HEX HEAD CAP SCREW, 1/2-13 x 5/8" LG.	5
15.	F081307HCS	HEX HEAD CAP SCREW, 1/2-13 x 7/8" LG.	5
16.	M12ETLW	EXTERNAL TOOTH LOCK WASHER, M12	10
		KITS:	
	20190	Service kit GP5800 Honda; includes the following.	
		#01000 (5) Shock Mount	
		#1690 (4) Shock Mount	
		#05881 V-Belt, A37	
		#19951 Oil, 10W30, One Quart	
		#20186 Exciter Oil, 8 oz. Bottle	
		#Q17210ZE2515 AIR CLEANER ELEMENT	
		#Q9807956846 SPARK PLUG	

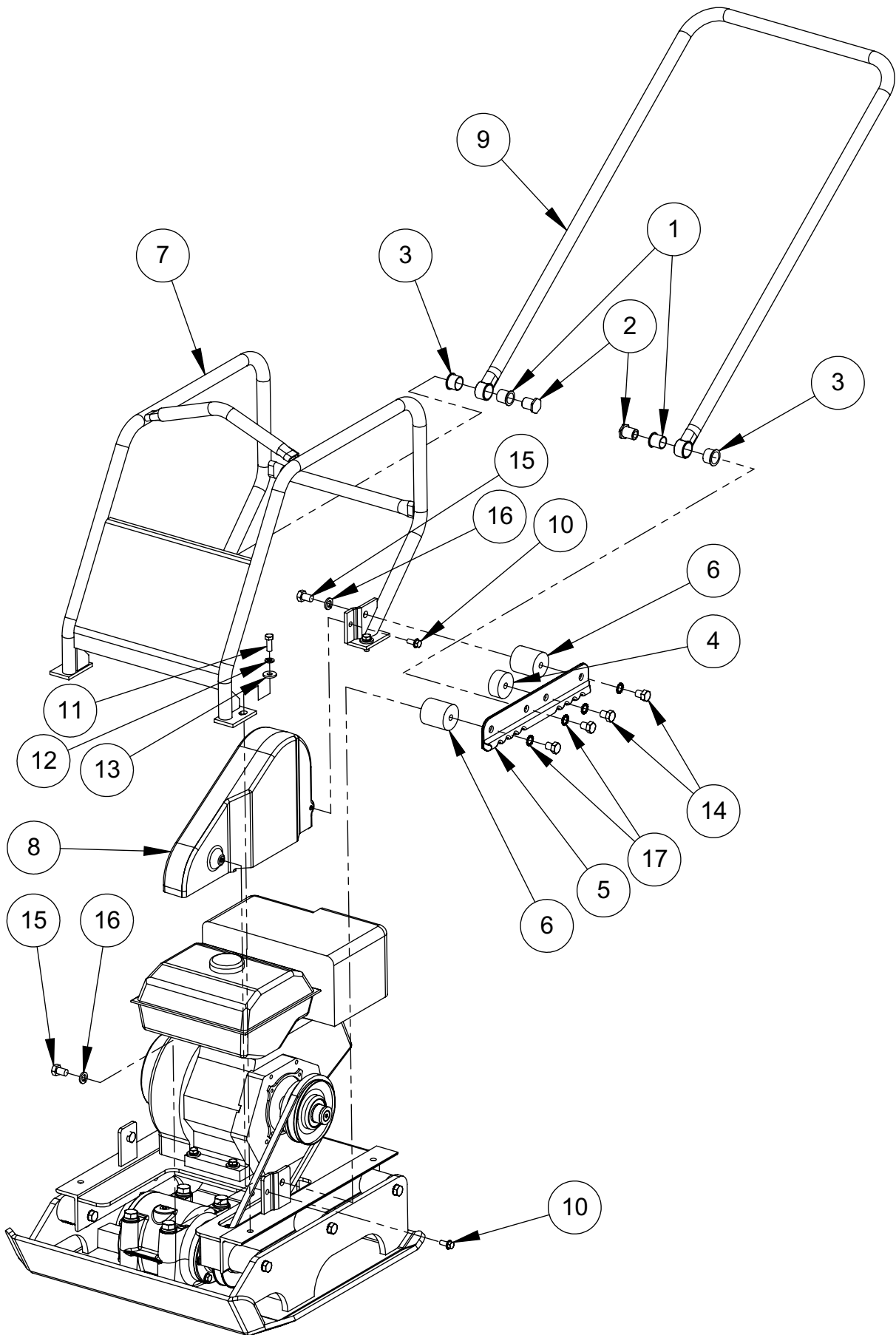

Roll Cage Assembly

ITEM	PART NO.	DESCRIPTION	QTY
1.	01019	HANDLE BUSHING, INNER	2
2.	15830	HANDLE ATTACHMENT NUT	2
3.	16191	HANDLE BUSHING, OUTER	2
4.	16189	SHOCKMOUNT	2
5.	21665	KIT, LIFT HANDLE	1
6.	16908	SHOCK MOUNT, HANDLE	4
7.	19999	ROL CAGE, 5800	1
8.	20009	BELT GUARD	1
9.	20010	HANDEL ASSEMBLY (Includes items #1 & #3)	1
10.	F051806FWS	FLANGE HEAD LOCK SCREW, 5/16-18 x 3/4" LG.	2
11.	F061608HCS	HEAX HEAD CAP SCREW, 3/8-16 x 1" LG.	4
12.	F06LW	LOCK WASHER, 3/8"	4
13.	F06SW	FLAT WASHER, 3/8"	4
14.	F081305HCS	HEAX HEAD CAP SCREW, 1/2-13 x 5/8" LG.	8
15.	F081306HCS	HEAX HEAD CAP SCREW, 1/2-13 x 3/4" LG.	4
16.	F08LW	LOCKWASHER, 1/2"	4
17.	M12ETLW	LOCK WASHER, M12 EXTERNAL TOOTH	8

WARRANTY

WHAT DOES THIS WARRANTY COVER? MBW, Incorporated (MBW) warrants each New Machine against defects in material and workmanship for a period of twelve (12) months. "New Machine" means a machine shipped directly from MBW or authorized MBW dealer to the end user. This warranty commences on the first day the machine is sold, assigned to a rental fleet, or otherwise put to first use.

MBW warrants each Demonstration Machine against defects in material and workmanship for a period of six (6) months. "Demonstration Machine" means a machine used by MBW or its agents for promotional purposes. This warranty commences on the first day the machine is sold, assigned to a rental fleet, or otherwise put to first use.

This warranty covers the labor cost for replacement or repair of parts, components, or equipment on New Machines or Demonstration Machines, and MBW shall pay labor costs at MBW's prevailing rate to affect the warranted repair or replacement. MBW reserves the right to adjust labor claims on a claim-by-claim basis.

This warranty covers the shipping cost of replacement parts, components, or equipment via common ground carriers from MBW to an authorized MBW dealer. Air freight is considered only in cases where ground transportation is not practical.

MAY THIS WARRANTY BE TRANSFERRED? This warranty is non-transferable and only applies to the original end user of a new machine or demonstration machine.

WHAT DOES THIS WARRANTY NOT COVER?

1. This warranty does not cover any Used Equipment. "Used Equipment" means any MBW machine or equipment that is not a New Machine or a Demonstration Machine. All Used Equipment is sold **AS IS/WHERE IS WITH ALL FAULTS**.

2. This warranty does not cover any New Machine, Demonstration Machine, or their equipment, parts, or components altered or modified in any way without MBW's prior written consent. This warranty does not cover the use of parts not specifically approved by MBW for use on MBW products. This warranty does not cover misuse, neglect, shipping damage, accidents, acts of God, the operation of any New Machine or Demonstration Machine in any way other than recommended by MBW in accordance with its specifications, or any other circumstances beyond MBW's control. This warranty does not cover any New Machine or Demonstration Machine repaired by anyone other than MBW factory branches or authorized MBW distributors.

3. This warranty does not cover, and MBW affirmatively disclaims, liability for any damage or injury resulting directly or indirectly from design, materials, or operation of a New Machine or Demonstration Machine or any other MBW product. MBW's liability with respect to any breach of warranty shall be limited to the provisions of this document and in no event shall exceed an amount equal to the purchase price of the New Machine or Demonstration Machine purchased from MBW.

4. This warranty does not cover engines, motors, and other assemblies or components produced by other manufacturers and used on a New Machine or Demonstration Machine, as said engines, motors, and other assemblies or components may have warranties provided by the manufacturer thereof. This warranty does not apply to consumable items, such as v-belts, filters, trowel and screed blades, seals, shock mounts, batteries, and the like, all of which are sold **AS IS/WHERE IS WITH ALL FAULTS**.

5. This warranty does not cover the cost of transportation and other expenses which may be connected with warranty service but not specifically mentioned herein.

6. This warranty does not cover any updates to any New Machine, Demonstration Machine, or any other MBW product. MBW reserves the right to improve or make product changes without incurring any obligation to update, refit, or install the same on New Machines or Demonstration Machines previously sold.

WHAT MUST YOU DO TO OBTAIN WARRANTY COVERAGE? Each New Machine or Demonstration Machine is accompanied by a Warranty Registration Card. You must sign, date, and return the Warranty Registration Card to the place of origin of the New Machine or Demonstration Machine, either to MBW, Inc. at P.O. Box 440, Slinger, Wisconsin 53086, MBW (UK), Ltd. at Units 2 & 3 Cochrane Street, Bolton BL3 6BN, United Kingdom or MBW FRANCE SARL at ZA D'Outreville, 5 Rue Jean Baptiste Neron, Bornel 60540 France, within ten (10) days after purchase, assignment to a rental fleet, or first use. This signed warranty card is the buyer's affirmation that he has read, understood, and accepted the warranty at the time of purchase. Failure to return the warranty card as specified herein renders the warranty null and void. In order to receive warranty coverage consideration, warranty claims must be submitted within thirty (30) days after the New Machine or Demonstration Machine fails. Warranty claims must be submitted to MBW, Inc., MBW (UK), Ltd. or MBW FRANCE SARL, and written authorization for the return of merchandise or parts under the warranty must be obtained before shipment to MBW.

WHAT WILL MBW DO? MBW's obligation under this warranty is limited to the replacement or repair of parts for a New Machine or Demonstration Machine at MBW factory branches or at authorized MBW distributors, and such replacement or repair is the exclusive remedy provided hereunder. Labor must be performed at an authorized MBW distributor. MBW reserves the right to inspect and render a final decision on each warranty case, and MBW's repair or replacement is solely within the discretion of MBW.

IT IS EXPRESSLY AGREED THAT THIS SHALL BE THE SOLE AND EXCLUSIVE REMEDY UNDER THIS WARRANTY. UNDER NO CIRCUMSTANCES SHALL MBW BE LIABLE FOR ANY COSTS, LOSS, EXPENSE, DAMAGES, SPECIAL DAMAGES, INCIDENTAL DAMAGES, OR PUNITIVE DAMAGES ARISING DIRECTLY OR INDIRECTLY FROM THE USE OF THE NEW MACHINE OR DEMONSTRATION MACHINE WHETHER BASED UPON WARRANTY, CONTRACT, NEGLIGENCE, STRICT LIABILITY, OR ANY OTHER LEGAL THEORY.

THE FOREGOING WARRANTY IS EXPRESSLY IN LIEU OF ALL OTHER WARRANTIES, EXPRESS OR IMPLIED, INCLUDING THE WARRANTIES OF MERCHANTABILITY, FITNESS FOR USE, AND FITNESS FOR A PARTICULAR PURPOSE, AND ALL OTHER OBLIGATIONS OR LIABILITY ON MBW'S PART. MBW NEITHER ASSUMES NOR AUTHORIZES ANY OTHER PERSON TO ASSUME ON BEHALF OF MBW ANY OTHER LIABILITY OR WARRANTY IN CONNECTION WITH THE SALE OR SERVICE OF ANY NEW MACHINE, DEMONSTRATION MACHINE, OR ANY OTHER MBW PRODUCT.

EXTENDED RAMMER WARRANTY - MODELS R422, R442, R482 & R483.

This extended warranty commences on the last day of MBW's standard, one year, "limited warranty" and runs for an additional four years (48 months). This extended warranty is limited to part replacement and shipping costs of rammer **bellows and non-metallic slide bearings only**. This extended warranty does not cover labor, down time, or any other cost beyond that of component replacement and freight. This extended warranty is subject to all limitations set fourth in MBW's "limited warranty", above.